



KNX Solutions

Content

Energy Efficiency in Houses	2
Energy Efficiency in Industrial Buildings	3
Energy Efficiency in School Buildings	4
Energy Efficiency in sports halls	5
Smart Metering & Smart Building	6
Renewable Energy	7
Heating, Ventilation & Air Control (HVAC)	8
Safety & Surveillance	9
Sun Blind Control	10
Ambient Assisted Living	11
Elevator control	12
Kitchen control	13
Fire Alarm Systems	14
Gateways	15
IP Control	16
LED Control	17
Audio & Video Control	18
Telephone control	19
iPhone® Control	20
WLAN Control	21
Social Networks	22
Scenarios in a holiday paradise	23
An example for energy efficiency in Southern Europe	24
Excellent study atmosphere in desert campus	25
Highest level of efficiency for Singapore's skyline	26
Pioneering building system technology on Australia's famous Surf Coast	27
Intelligence of stellar architecture	28
Factory recycles waste heat from production	29
KNX competence for Finland	30
Together with KNX on an eco journey	31
Bus technology ripe for the island	32
Intelligent control makes airport more efficient	33
Diploma with a global standard	34
The Smart Home on the curriculum	35

Energy Efficiency in Houses

Task

The rising cost of energy together with a more careful use of energy have moved up on our society's agenda. For this reason, we need new solutions for the optimization of energy management – something that can be achieved by applying the KNX standard.

The Solution

Where KNX systems are installed, the residents are informed about their current energy consumption so that they can use it in the most economical way. When KNX is used to control and monitor the various domestic applications, total energy consumption will be reduced. Moreover, users can monitor their actual energy use on visual displays and have the opportunity to take action in order to reduce their consumption as much as possible, whether they are at home or away from it.

Implementation

Solutions for an average home:

- Lighting control (MECEL) with capacity for the control of the whole house in zones or as a group.
- HVAC control with KNX (Intesis) capable of controlling any equipment on the market.
- Touch screens (JUNG and Zennio) will provide visual displays of the house.
- A GPRS module (Analuslabs) will allow users to control the system when in the house or away from it.
- Smart Metering devices and software (Multidomo Networks) for metering the consumption of energy, water, gas etc.

Features

- Dimming of lighting to suit users' needs
- Optic fiber sensors for better night-time signaling

- Different scenarios, according to the users' needs
- Monitoring for system overload
- Integrated thermostat for easier use and control of HVAC equipment in order to get the best use
- Real-time monitoring and recording of data (temperature, consumption of energy, water, gas...) providing a general overview of use and allowing users to take further actions
- Smart metering consumption will make users aware of wasted energy, allowing them to save energy and money.
- The timer can be re-configured to suit individual needs and can also be stopped at any time.

Advantages

By integrating all applications into one single KNX installation, users have many options for easy and comprehensive monitoring with a control system that is intuitive to operate and use. In addition, there are the following advantages:

- The optic fiber sensors can be installed in any part of the house.

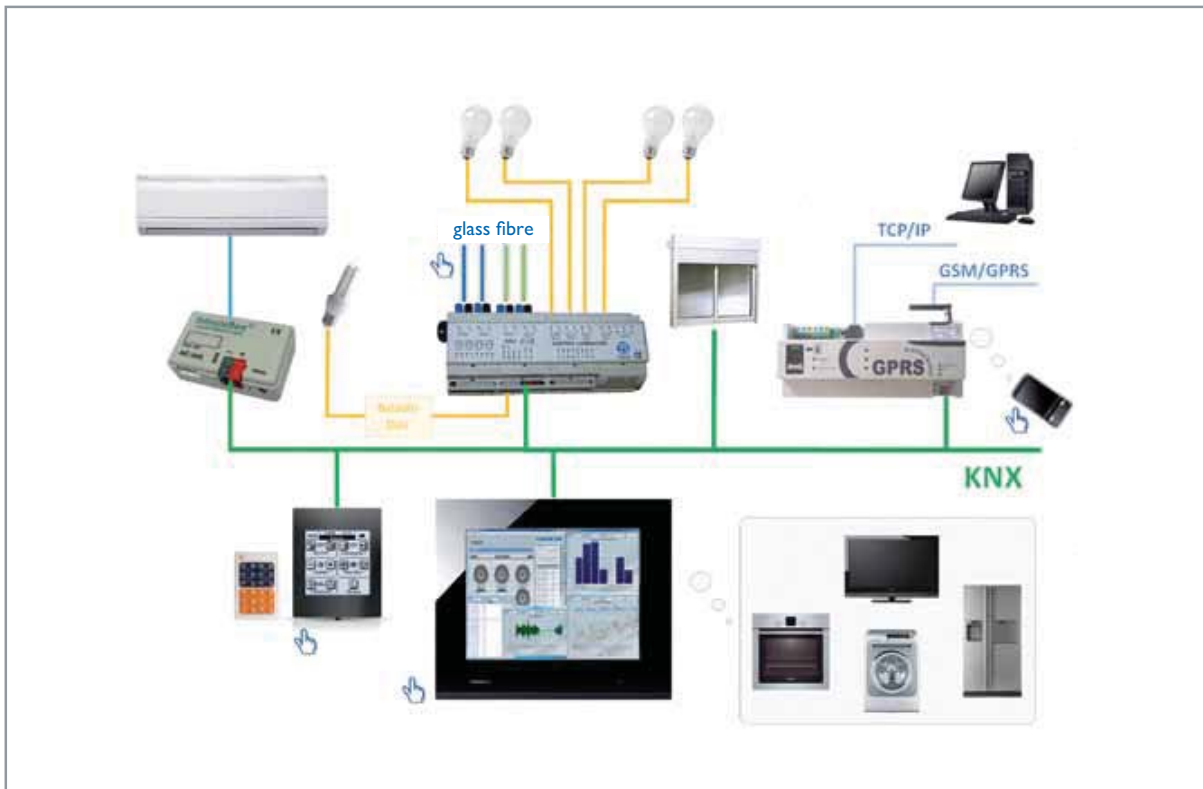

Energy Efficiency in Industrial Buildings

Assignment

Elektro Hieber from Schwabmünchen presents the KNX installation of a 5700 m² factory. 24 hour operations require artificial light for certain periods and certain areas. The ventilation depends on machine activity, whereas waste heat is recovered for heating purposes. To achieve energy efficiency and cost savings, the customer opted for smart building automation.

Solution

The KNX bus system allows the integration of components for the automation of lighting, ventilation, heating and alert management. Individual functions can be connected via the network for central operation and control.

Realisation

The complete lighting system consists out of 616 fluorescent lamps, controlled via DALI and KNX/DALI gateways (Siemens). Presence

detectors (ThebenHTS) and dimmers ensure that all lighting components are used with maximum energy efficiency depending on presence of personnel and daylight. Thanks to KNX, an emergency lighting system approved by TÜV (Technischer Überwachungs-Verein, German Technical Inspection Association) could be integrated into the lighting installation.

Ventilation flaps used as smoke outlets, for heat dissipation and for additional air circulation are controlled via temperature sensors (Arcus-eds). For this purpose, KNX detects the number of machines in operation via an M-Bus interface. The system uses different settings for summer and winter operation. If the room temperature exceeds the set point in summer, the interior and exterior ventilation flaps are opened. In winter only the

interior ventilation flaps are opened so that excess heat is used for heat recovery.

Via temperature sensors, the KNX system controls the installed radiant tube heaters used for Room heating. KNX binary input modules (ABB) pick up fault messages from the building automation system and from production. The messages are forwarded to a facility server from Gira where they can be displayed and processed by the responsible staff. Set points, switching times and other parameters can be set via the password-protected access point where they also can be visualised.

Technical Highlights

- Efficient lighting technology controlled according to customer requirements.
- Integrated emergency lighting system approved by

TÜV (German Technical Inspection Association).

- Integration of existing fire protection concept for improved action in case of fire.
- Intelligent temperature management with recovering of waste heat.
- Efficient ventilation according to the requirements of the respective production process.
- 3D visualisation for easier handling and control.

Advantages

Energy savings of 30% for lighting. Required heating energy cut by half because of recovering waste heat from production. Power consumption of ventilation motors reduced to 70% compared to the not automated operation. Yearly savings: About 50.000 Euro – in addition to other benefits, like higher efficiency.

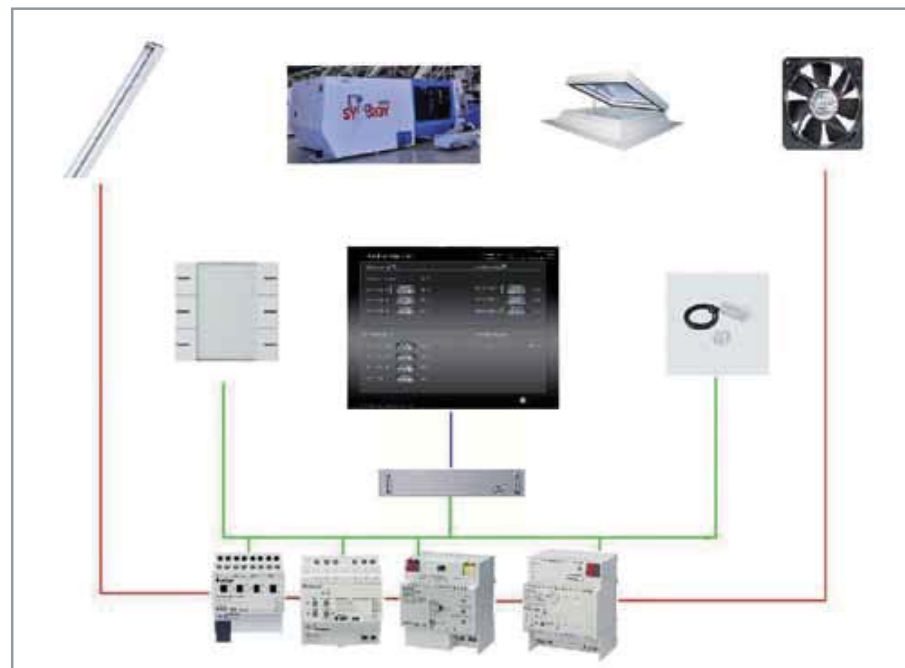

Energy Efficiency in School Buildings

Task

Proposals are being sought for new construction and refurbishment of school buildings. Functions to be covered are lighting, solar screening and heating as well as, increasingly, ventilation. An important objective of KNX automation systems is energy efficiency, the local control of which is a particular priority during school hours. It is intended that the energy conservation measures are also demonstrated to the pupils for educational purposes.

Solution

Lighting in the classrooms is switched on and off manually, activating a movement sensor with constant lighting control which will automatically switch off the light after the lesson. The KNX controls of the blinds ensure precise screening with optimum daylight levels during lessons; when the room is not occupied they will close for cooling in the summer and open up for solar gain in the winter. For the heating system, operating modes such as

'comfort', 'economy' and 'frost protection' will be activated automatically in accordance with the lesson and holiday schedules. The rooms are ventilated via electrically operated windows. It is still possible to open the windows manually, but the KNX CO₂ sensors will detect stale air levels and activate automatic opening. For education purposes, the energy consumption data is available on the display system or on the internet. This includes the CO₂ values as a result of the ventilation function.

Implementation

The following products are installed on the panel:

- An Amun 760 (Theben) CO₂ sensor measures the CO₂ concentration and current temperature/humidity in the room
- Windowmaster NV Comfort as the central unit for natural ventilation uses measured data to calculate window control strategy
- Windowmaster Motorcontroller WEC 16M including

drive controls and opens/closes the windows

- A KNX/Dali Gateway (Gira) controls the lighting, including dimming function
- A movement sensor (Busch-Jaeger) takes care of constant lighting control and detecting the presence of people
- The Ambientomura (TCI) touch screen with visualization software facilitates operation and displays functions and data.
- A radio transmitter and KNX RF media coupler (Hager) can be used to provide the data in refurbishment projects.
- In addition, there is a KNX water meter (Arcus-EDS) which monitors the sanitary facilities for excessive use of water.

Functions

The light is switched on at the start of lessons. The constant lighting control can be started up by shining an external lamp (flashlight) at the sensor. A bus button is used for manual dimming, which will de-activate the constant lighting control. The

current CO₂ concentration is displayed in a diagram. When the value changes, the window opens slowly. For optimising the ventilation functions it is possible to set the parameters at the NV Comfort Panel. All consumption data in the rooms is displayed to suit educational purposes.

Advantages

- Energy efficiency through KNX automation with manual operation a priority.
- Automatic natural ventilation with the option of manual ventilation when this is required due to rapidly changing requirements.
- Educational format of information to increase pupils' energy awareness.

Ingenieurbüro Beyer
Gebäudesystemtechnik
Dipl.-Ing., Dipl.-Wirt.-Ing. Dirk Beyer
Liegnitzer Str. 10
24537 Neumünster, Germany
Phone: 04321 / 9938-0
Fax: 04321/9938-28
Mail: info@ing-beyer.de
www.ing-beyer.de

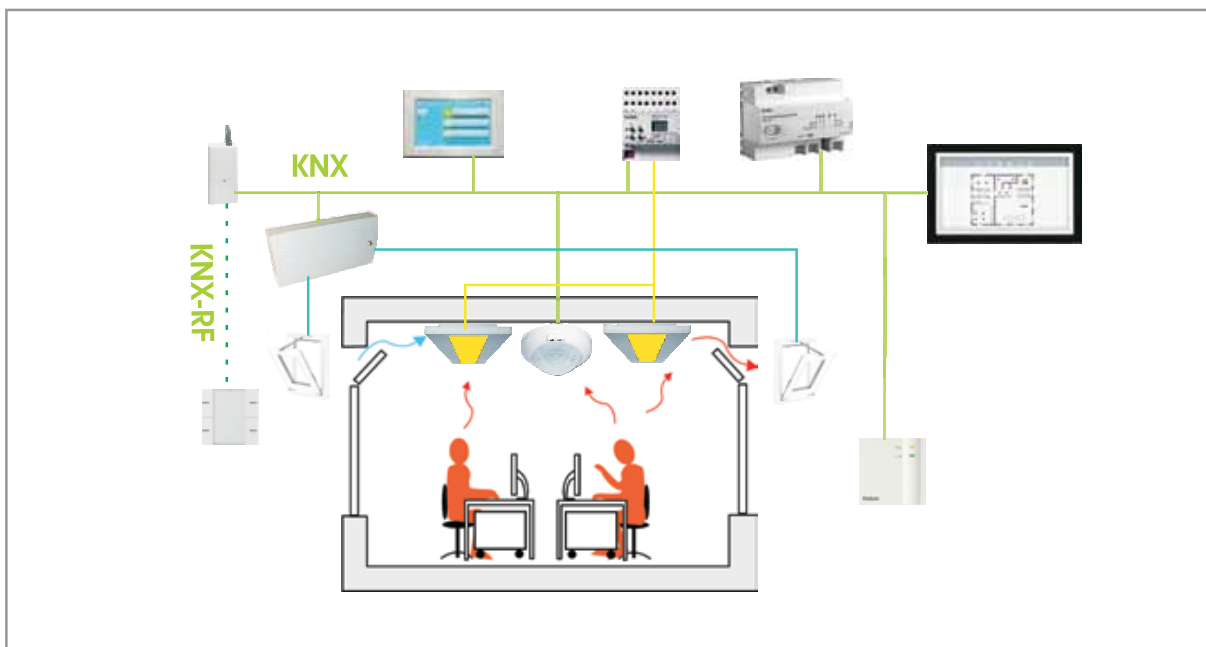

Energy Efficiency in Sports Halls

Assignment

Energy use in sports halls for lighting, heating and ventilation is considerably high. This is because of the specific architectural structures used for these types of buildings. Users often forget to switch off the lights and in many cases the ventilation is permanently running. Energy savings can be achieved by using demand-related controls.

Solution

Presence detectors are not ideal in halls with heights up to 6-8 metres. Detection works well for clearly distinguishable movements, difficulties occur however for quieter activities such as yoga classes. The lights could in cases like the latter be switched off unwantedly. The engineering company Beyer uses an optical sensor to solve this problem.

Realisation

A CCTV dome camera system with KNX/IP interface (by Dallmeier) surveys the activity area for the presence of persons. The intensity of movement is irrelevant for this process. If desired, the camera can be used in order to prevent vandalism and hence to alarm personnel.

The lighting system of the sports hall is manually switched on and off via a robust KNX panel with eight push buttons and LED display (by GePro) located at the entrance. The default brightness setting is "school sports" (200 Lux). Energy actuators with current detection (by ABB) deliver metering data. Via a touch panel in the control room (by Gira), the brightness can be increased to 300 Lux for training or 500 Lux for sport contests. Fan coil actuators (by Theben) control the HVAC devices.

Features

The lights are switched off automatically if the optical sensor detects an empty sports hall and when this state continues for several minutes. On the panel, users are informed about the energy consumed since the lighting was switched on last time.

Optical sensors are suitable to control HVAC systems efficiently. They are able to detect the number of persons with a sufficient accuracy of approximately 80%. This information can be used to see how many people are in the hall and hence to set the HVAC controls accordingly.

Advantages

The installation offers possibilities to save energy in sports halls.

If the metering information is saved, users of the hall can be charged according to energy consumed.

As public awareness for energy efficiency is growing, the system offers a useful and very simple feature: the possibility to display current energy consumption on a large public screen.

Energy efficiency in sports halls is increased when the number of persons is counted and if the HVAC system is controlled accordingly. This kind of functionality can also be very effective for training and seminar rooms.

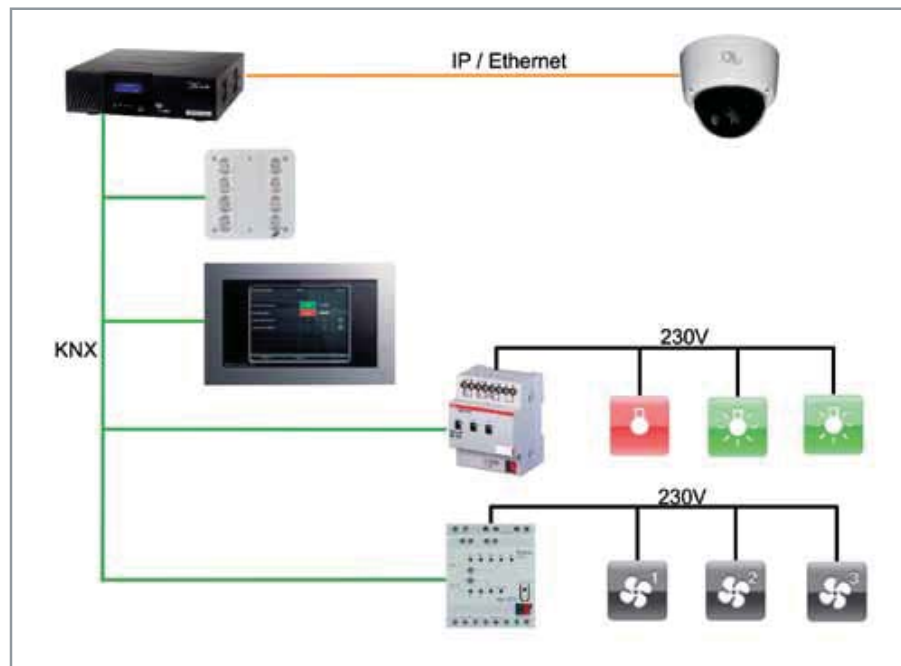

Smart Metering & Smart Building

Task

KNX is a worldwide standard for home and building control, offering new products in the market of visualization and smart metering. The increasing number of products by different KNX manufacturers in this market segment provides a good variety of installation options. In addition, it is intended to demonstrate the option of installing active tariff management.

Solution

The use of metering for electricity, heat consumption, fill level monitoring and water meters with electronic data recording and storage facility ensures the safety of the system in case of power failure. Complete visualization of the data with integrated consumption display and diagrams is available and easy to configure. This solution makes it possible to record and monitor the consumption of each KNX unit connected to the system.

Implementation

By connecting the sensing devices to the KNX bus system and linking this with the IP domain it is possible to display and process the respective data on the touch panel. The software by Promoveo-Technology is used to record and evaluate the data so that users can readily see the consumption of the various media, i.e. electricity, water, gas, solar and heating in the past and the consumption can be extrapolated for the following week. To benefit from different electricity tariffs, it is possible to use power-intensive equipment during the cheaper periods. In this way users of this technology can react to tariffs as they change and use them to their advantage.

Functions

- Display of electricity tariff (cheap, expensive)
- Heat consumption meter with KNX interface
- Electricity meter (different types of energy meters with flexible IR-interface)

- Water meter with KNX interface
- Control of filling levels for tanks (oil, water, liquids)
- Evaluation of consumption data and display in diagrams
- Display of consumption levels - high, average, low - represented by red, yellow, green
- Display of electricity tariff with the option of manually connecting or disconnecting electrical equipment

Benefits

The system represents a worldwide standard and can be used to display the consumption of different types of energy in buildings. The customers can check their consumption data by pressing a button. The energy management software can be used to connect or disconnect power-hungry equipment (washing machine, dishwasher etc.) to benefit from cheaper tariff periods. KNX helps to use energy more economically while enhancing comfort and security.



KOYNE
SYSTEM ELEKTRONIK

Koyne-System-Elektronik
intelligentes Wohnen
Marco Koyne
Dipl.-Ing. (BA) Elektrotechnik
Automatisierung
Duchrother Str. 38
12559 Berlin, Germany
Phone: +49 (0)30 - 47 03 21 82
Fax: +49 (0)30 - 47 03 21 83
Mail: info@koyne-system-elektronik.de

Renewable Energy

Task

eSolar is a supervision and local/remote maintenance management system for photovoltaic (fixed or solar tracking) plants. The system consists of low energy consumption hardware, installed in each photovoltaic plant, which can universally acquire data. eSolar integrates a domotic engine that communicates through the KNX protocol. Web access to the device is possible via LAN or mobile networks like GPRS/UMTS. Installed in a control center, this server allows the parallel monitoring of several plants. i.e.

- real time monitoring of the correct functioning of all components of a photovoltaic plant
- periodically picking up data coming from different plants
- management of logging data of several plants
- comparative analysis of production and performance of different plants

- management of technical and economical history for maintenance purposes.

Solution & Implementation

eSolar can communicate with the majority of commercially available inverters through RS232 or RS485 serial communication ports to acquire the measured source. It can also communicate with energy counters, tax counters or net analyzers through its communication ports RS232 or RS485 or impulsive outputs to acquire the measured source. Through KNX, eSolar can acquire data coming from different kind of commercially available sensors to realize the necessary action (temperature and other environmental parameters, automatic actuating system for cooling and cleaning of photovoltaic modules, photovoltaic tracking systems control, electric load management etc.).

It can record and store data on a daily, monthly and annual basis for ten years and permits graphical or table visualization of this data. eSolar can, autonomously and automatically, supervise data and initiate scenarios or scheduling depending on events (dispatching of alarm signals through e-mail or SMS, initiation of cleaning operations in case of dysfunctional performance decrease, control of electric loads, generation of production reports, start of scenarios and schedules depending on real-time comparison of energy production and plant load curves, signalling and actuations start up in case of theft attempt etc.).

Features & Advantages

- Guaranteed communication with the majority of the commercially available conversion and energy counting systems, as well as with standard sensors for the collection of environmental parameters.

- Thorough and detailed information on energy production, its efficient use and benefits and generated savings.
- Real-time information from supervised plants for maintenance and properly timed interventions
- Communication with home and building automation systems is a strategic function enabling load management, creation of energy policies, initiation of domotic scenarios, and an increase of building energy efficiency.

sinapsi
SYSTEM INTEGRATOR

SINAPSI s.r.l.
Via Delle Querce, 11/13
06083 Bastia Umbra (PG), Italy
Phone: +39 075 801 04 73
Fax: +39 075 801 46 02
mail: info@sinapsi-online.com
www.sinapsi-online.com

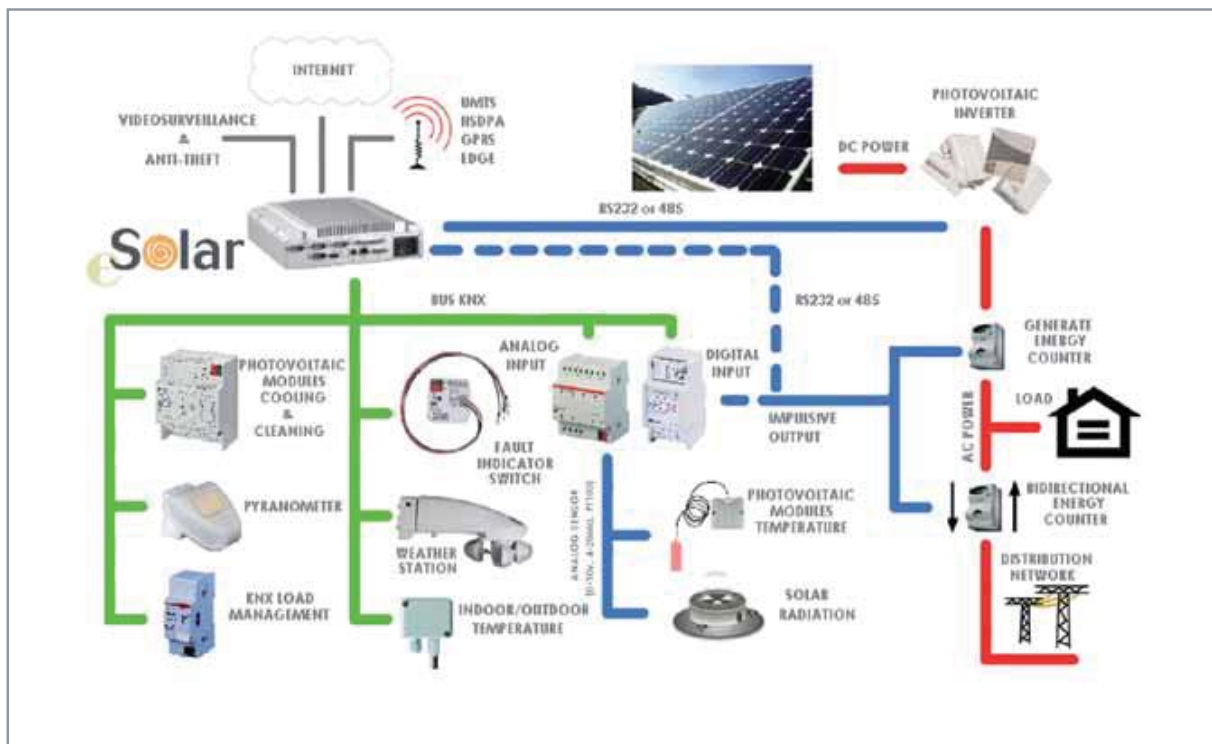

■ Heating, Ventilation & Air Control (HVAC)

Task

The archives of a District Council require a central control system as well as remote control for its lighting, blind and security systems and, in particular for the heating, ventilation and air conditioning. Special focus is on maintaining the values for air quality and those required under the Workplaces Directive.

Solution

Beger and Sporleder produce a model presentation of the KNX system implemented by EGB. The equipment and systems for sensors, actuators and displays are provided by different KNX manufacturers. The selection of these focused on optimum functionality and economy. In addition to KNX TP, the transmission medium KNX RF is used. The central operation uses a visualization screen and touch panel.

Implementation

The air quality values in the offices and archives are measured by sensors (Elsner) for temperature, humidity and CO₂ content. These values are used by the IRSC (Zennio) air conditioning controller to control the split air conditioning units and by the KNX controller (Buderus) to control the heating system. A KNX weather station supplies further data for the lighting, the blind system etc., such as precipitation, wind speed, daylight levels and a DCF77 time signal. A visualization was selected for the central operation and display of faults, measured values, operational and switch status. This will also link the building functions and transmit the data, alarm and fault messages to a facility management system via intranet and the telephone network. This system also makes it possible to carry out remote parameterization via the ETS.

Functions

The visualization is used for central operation and provides technical personnel with the operating status and messages, both internally and externally. Manual operation is possible from remote locations as is the receipt of messages by a mobile phone with internet connection. Settings for lighting, air conditioning and ventilation can be set automatically in accordance with the service schedule. Likewise, when the lock system registers contact from the locking bolts, the operating status, such as 'standby' or 'comfort temperature' for the respective building area will be set automatically. For monitoring the air quality in the archives, data for CO₂, humidity and temperature are recorded and saved automatically.

Advantages

KNX proves its strength particularly when it comes to complex applications: simplified installation, multiple benefits for different applications and flexibility regarding changes in user programs. In addition, the system can be used for remote control where this is required due to the location of the properties.



EGB
ELEKTRO UND GESÄNDERTUMBAU FALK BEGER

EGB Falk Beger
Intelligent solutions for residential and commercial properties
09633 Halsbrücke, Germany
Phone: +49 3731 300 97 27
www.egb-beger.de



SPORLEDER
Wohne mit Funktionen

Sporleder
Elektro Technik GmbH
30453 Hannover, Germany
Phone: +49 511 213 33 22
www.wohnen-mit-funktionen.de

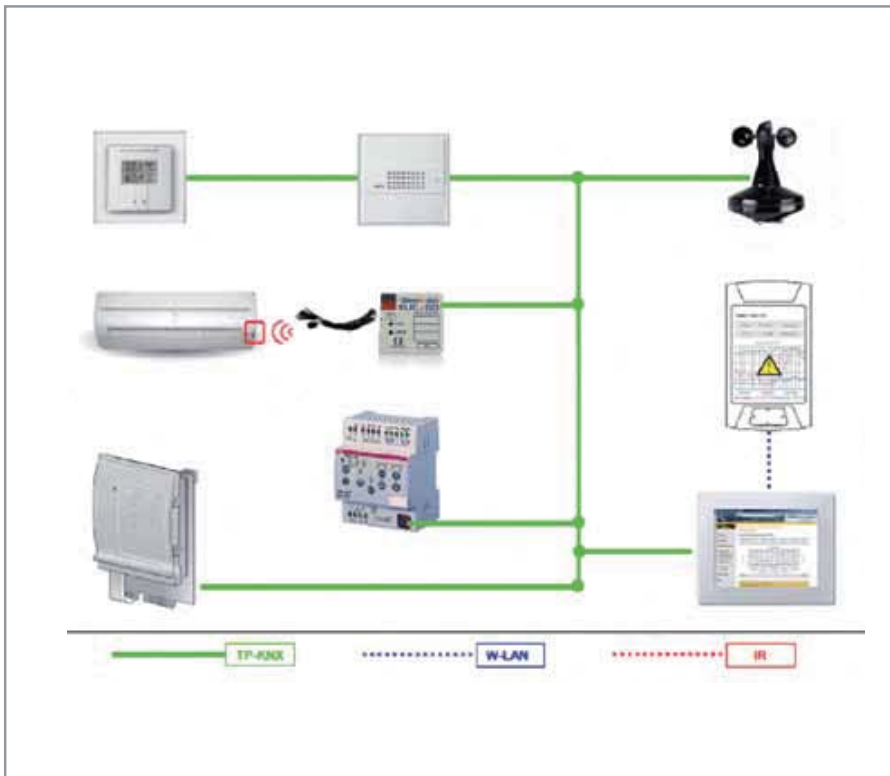

Safety & Surveillance

Task

Gepro, located in Stralsund, offers practical applications for a broad range of uses such as offices, restaurants, hotels, exhibitions, theatres, swimming pools, sports complexes, zoos etc. The installation demonstrates how security functions can be integrated into KNX installations. A clear concept of use for commercial applications is of special importance to Gepro.

Implementation

A VDS burglar alarm (L240 ABB) with a visible LCD user panel and an LED flashing beacon are central components of the installation. Motion detectors (HTS) and window contacts are installed to demonstrate how burglar intrusion can be detected. Fire alarms for KNX (Siemens) and water detectors (Lingg & Janke) are shown as an exam-

ple for additional security and monitoring functions. A touch display is used to visualize these functions. Additional operator devices for arming the alarm system and for function displays are realized as pushbutton panels with LEDs (GePro): key-operated switches can also be integrated. Peripheral components such as binary inputs (Theben), actuators (Zenio) dimmers and interfaces work invisibly in the background, while a server-box provides the logics, show effects etc.

Functions

Different functions can be demonstrated. When arming the circuit via a key-operated switch, an acoustic signal is used as confirmation. LEDs display all functional statuses. The switch used for arming the circuit is also used as a central on/off switch for the lighting system. After arming

the alarm system, motion detectors will trigger an alarm when a person is detected or a window contact is opened. A signal lamp is activated and an alarm is passed on as an SMS to a mobile telephone. When the alarm system is disarmed, the lighting can be switched on or off as usual via the pushbuttons. Motion detectors are used for automatic switching, and the status of window contacts can be used to display open windows and to turn off heating radiators. Alarm functions of smoke detectors and water detectors can be used for local display as well as for remote alarms.

Advantages

One system for all applications. Components can be used in multiple ways so that synergies are realized and bus installations can be put to additional use. Using KNX,

flexible security concepts can be put into practice with different functionalities, sensor applications, alarm management and user concepts. The demonstrated bus installation components for KNX comply with VDS (German notified body for accreditation of these systems) and are available on the market.

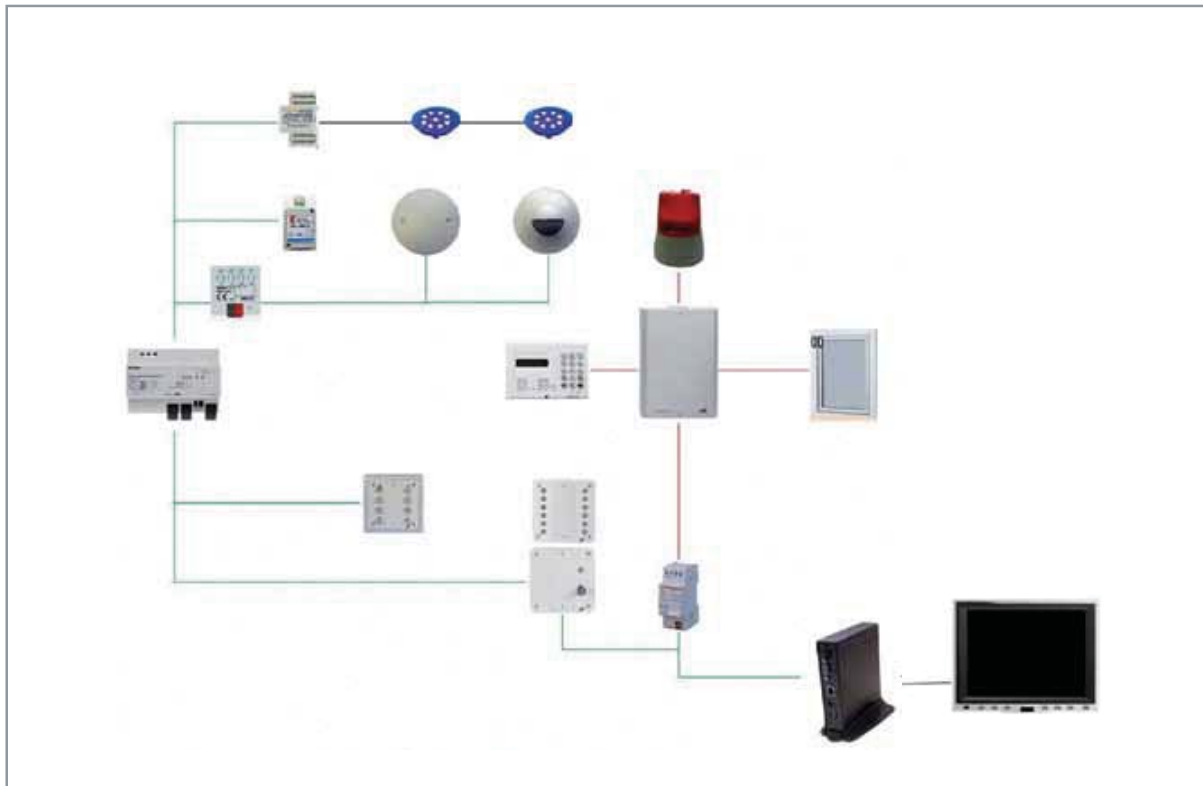

Sun Blind Control

Task

A sun-screening system in modern office buildings needs to fulfill two functions: ensuring comfort levels at the workplace and at the same time enhancing the energy efficiency of the building. The presentation shows a model of an installed system in an extensive building complex with several floors, internal courtyards and 2,500 solar screening sectors.

Solution

In order to achieve the best possible screening results for daylight levels, cooling in summer and heat-gain in winter, BMS selected KNX-based automatic solar tracking system.

Implementation

The equipment used for the sun blind control is the SunControlServer by BMS. A weather station with four centrally placed light level sensors provides data re-

garding solar radiation, wind and rain throughout the day. Movement sensors in the offices detect the presence of persons. Based on this data, the software controls the solar screening system, taking into account the sun's current position and angle of irradiation, and any shadows cast by parts of the building. The blinds are moved by conventional actuators. A visualization device is available to assist operation. It is also possible to operate the individual blinds manually.

Functions

When the sun is shining the blinds on the respective facades are activated to provide shade. This means that their louvres are adjusted such that daylight levels are optimized while avoiding glare. Artificial light is switched on via the movement sensors when required. If nobody is in the room, different commands are transmitted to the drives,

depending on the season: in summer the blinds will close fully in order to avoid heat gain. In winter the louvres open wide to allow solar gain.

Advantages

Through the automatic sun tracking device for each individual façade, a comfortable workplace atmosphere is achieved in all offices. Energy savings are achieved by reducing the use of artificial light, by maximizing heat gain in winter and minimizing energy used for cooling in summer. The SunControlServer software is suitable for single family dwellings and complex situations.

Building Management Systems
great systems for easy living.

BMS – Building Management Systems
Frank Lenders
Industriering Ost
47906 Kempen, Germany
Phone: 02152-95989-0
Fax: 02152-95989-1
Mail: Frank.lenders@bms-solutions.de
www.bms-solutions.de

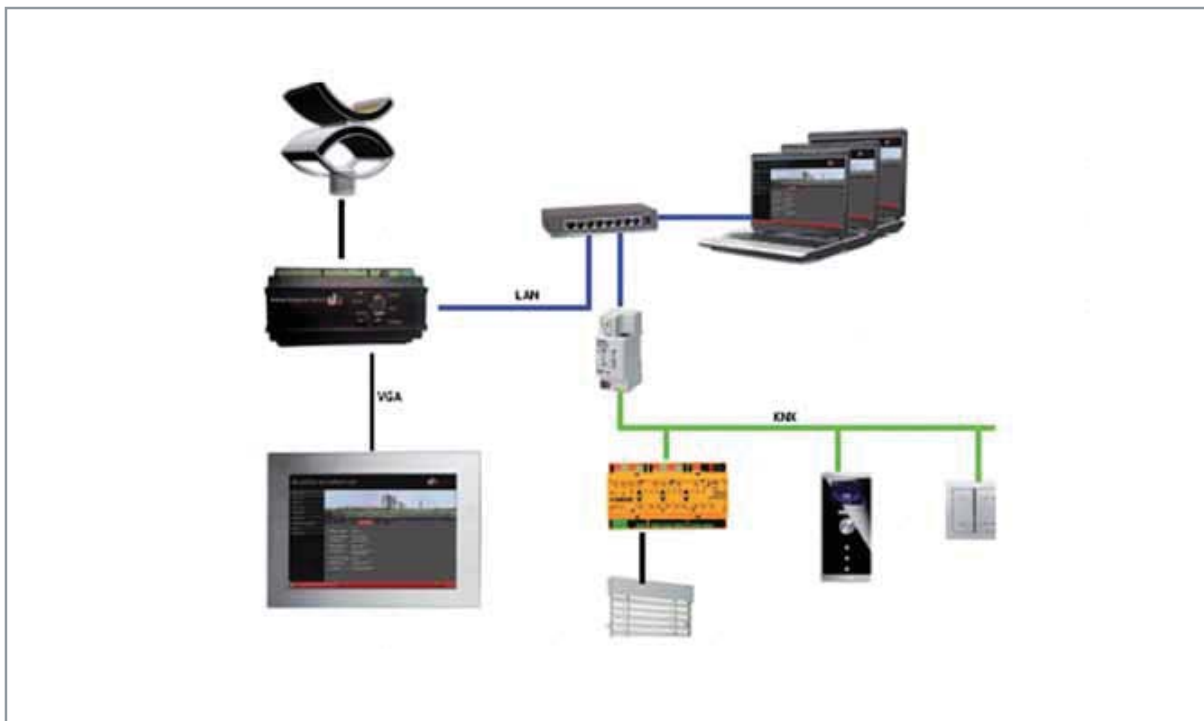

Ambient Assisted Living

Task

The term 'ambient assisted living' refers to living with technical support for older people. The reason is that more and more senior citizens wish to continue living in their own homes.

For this reason, many corporate landlords and private individuals modernize their properties not just from the energy point of view, but also to make them 'senior-friendly'. Cibek's presentation demonstrates how ambient assisted living (AAL) can be implemented with KNX.

Solution

Cibek is involved in grant-aided projects researching technologies that make it possible for older people to live in their own homes and offer safety in certain risk situations. The solution presented uses movement sensors for localization as well as information from the use of buttons for detecting

activities. The KNX standard is used because of its economy and versatility.

Implementation

The displayed concept shows examples of how one can upgrade existing homes using KNX TP and KNX radio components in order to improve comfort and safety. In addition to the KNX units, there is a mobile touch display for visualization, which has been specially developed for older citizens. A design study shows how one can use an iPod not only as a small, mobile visualisation display, but also as a multi-function switch for a senior-friendly operating concept, using a specially developed screen.

Functions

To demonstrate the functions the board was equipped with:

- UP units with switch actuators, blind actuators (Gira), KNX RF radio components (Siemens)

for activating the lighting, controlling the blinds and the heating system.

- Presence sensors (ABB) switch on the light automatically and in addition provide information about the presence of persons.
- The system is operated manually via a 5-gang bus switch with temperature controller (Gira) as well as via a mobile 12" 'senior touch display' (TCI).
 - The 'multi-functional button' is the outcome of a design study carried out by Cibek in cooperation with Gira.
- The following equipment is in operation at the back of the board: IP routers (ABB), voltage supply (Lingg&Janke), Cibek Mini-Server, Cibek Gateway and a WLAN node (for iPod).

addition, the data from installed sensors such as movement sensors, operating equipment etc., can be used for the detection of irregular patterns compared to the regular activities of the person, indicating situations in which help may be required and alerting the respective care service or relatives.

Advantages

KNX functions can be implemented as part of refurbishment in order to support ambient assisted living for older people. In

CIBEK®

Cibek technology + trading GmbH
 Justus Liebig Str. 15
 67117 Limburgerhof, Germany
 Phone: +49 (0) 6236 4796-31
 Fax: +49 (0) 6236 4796-39
 E-Mail: info@cibek.de

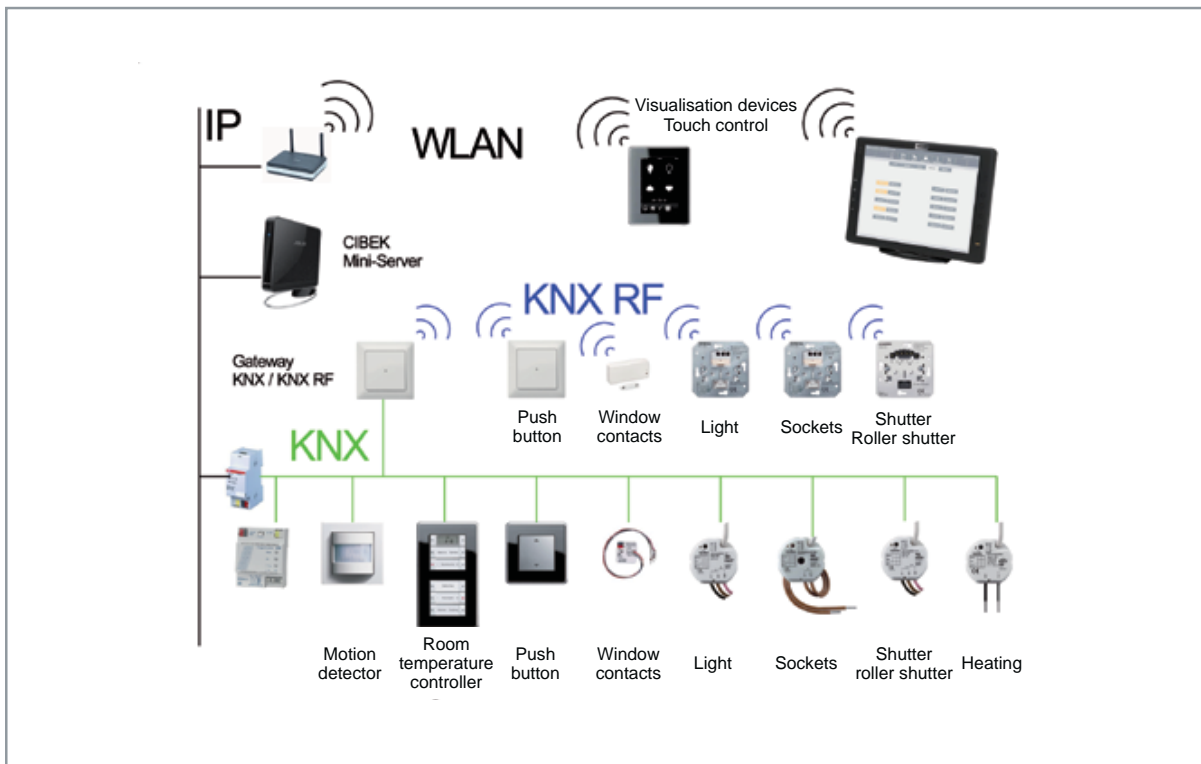

Elevator Control

Assignment:

It is common practice to switch off the lights, to turn down the heating and to cut off the coffeemaker from the mains via a central control when leaving the house. The integration of an elevator control into this central operating concept is a novelty. CIBEK presents their new KNX application „Lift Control“.

Solution:

The system integrator from Limburgerhof integrates the elevator control into a KNX system. This interface allows users to call the elevator from inside the flat and to receive status information about the elevator. An elegant feature of this solution is that the elevator call can be integrated into scenarios, like: “Arrival” and “Leaving”, etc.

Realisation:

The Cibek gateway is the central control and management unit. It is connected to the KNX installations of the individual flats, via KNX IP. Movement detectors (by Berker), pushbutton sensors (by Gira), actuators (by ABB), KNX radio components (by Jung), a weather station and a power supply (by Theben) build up the KNX environment. A KNX audio actuator (by WHD) is installed for media control. A home server is used as a communication interface between KNX and IP systems. KNX system functions and elevator control functions can be accessed via a Gira touch panel from within each flat. A 3D visualisation software serves as a common user interface, also for calls and images from the IP video-com.

Functions:

The touch panel serves as a single access point for both the KNX system and the elevator control. When calling the elevator, users can select immediate arrival, arrival within five or ten minutes etc. The management system coordinates elevator calls from all flats in the house. If scenarios are used, users can see e.g. weather information and the arrival time of the elevator, lights can be switched off and the heating set point can be lowered when calling the elevator, i.e. activate the “Leaving” scenario. When arriving at home, users can activate the “Arrival” scenario via a hand-held KNX radio control: the lights are switched on, the heating is set to comfort mode and music starts to play. Users can also select other customised functions together with the elevator call.

Advantages

- Comfortable and prestigious operating concept for high-end single and multi-family houses and apartment buildings.
- No more elevator waiting times in the hallway.
- Co-ordination of the elevator occupation/timing for all users.
- The system can also be used as a special solution for car lifts in hillside or terraced buildings, where inhabitants can park in front of their flats.
- Customisation of the central operating control functions is nearly infinite. Users can retrieve weather information or calendar details, select music or quickly place an order.

CIBEK®

Cibek technology
+ trading GmbH
Justus Liebig Str. 15
67117 Limburgerhof
Tel.: +49 (0) 6236 4796-31
Fax.: +49 (0) 6236 4796-39
E-Mail: info@cibek.de

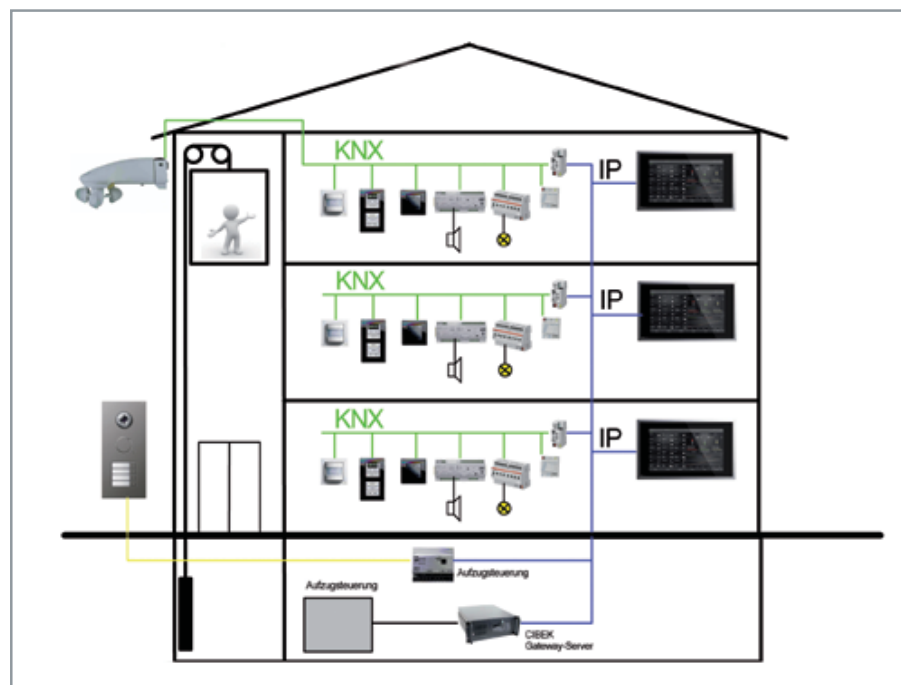

Kitchen control

Task

“Intelligent buildings“ integrate high-level comfort, security and energy efficiency. Requirements for central controls in kitchen technology should be equally high. EIB-TECH presents a functional and versatile visualisation of controls for all appliances and systems in the kitchen area. It's also great to look at! A requirement for the user interface: it should be easy to understand and simple to use for all members of the family.

Solution

As a KNX service provider, EIB-TECH offers a solution containing individually designed visualizations that allow integration of the entire kitchen technology into KNX systems. A remarkable feature of this KNX solution is a three-dimensional representation of floor plans, building elements and exterior views in the visualization. Users can see

entire rooms instead of two-dimensional floor plans. Icons that can be used to directly control all connected kitchen appliances show their current status or value.

Implementation

The visualization application is running on a touch panel device. Direct connection to the kitchen appliances is integrated via a gateway within the house or building is integrated: Actuators for switches, dimmers and blinds etc. Controls for individual rooms are installed as well as window contacts for multiple uses: they allow turning off heating radiators when the window is open, they are used to check the window status and they serve as a burglar alarm. Lighting scenarios for selected lamps, dimmer values and blind statuses can be combined and saved for later use.

Functions

- Switching and controlling of kitchen technology and kitchen appliances
- Temperature control and set-point adjustment for connected refrigerators
- Switching and dimming of lighting
- Use of pre-set lighting scenarios
- Composition of lighting scenarios with respective dimmer values
- Set-point adjustment and creation of temperature profiles for heating radiators.
- Documenting and querying of weather data (wind, rain, daylight)
- Checking of windows and doors
- Control of media systems etc.
- The visualization application gives users access to internet functions such as weather service, schedules, telephone calls, e-mail etc.

Advantages

- A high-end control center that has been designed with users in mind: it can be visually and functionally adapted to the specific requirements of kitchen users.
- Ease of use for the whole family as well as access to system functions for experienced users.
- A great variety of design touch panels allows all KNX users to find their own attractive control center.



EIB/KNX-Systemintegration
EIB TECH
 Helmut Lintschinger
 Kugelspielweg 13
 82346 Andechs, Germany
 Phone: +49 (0)8152/99 89 907
 Fax +49 (0)8152/99 89 908
 info@eib-tech.com
 www.eib-tech.com

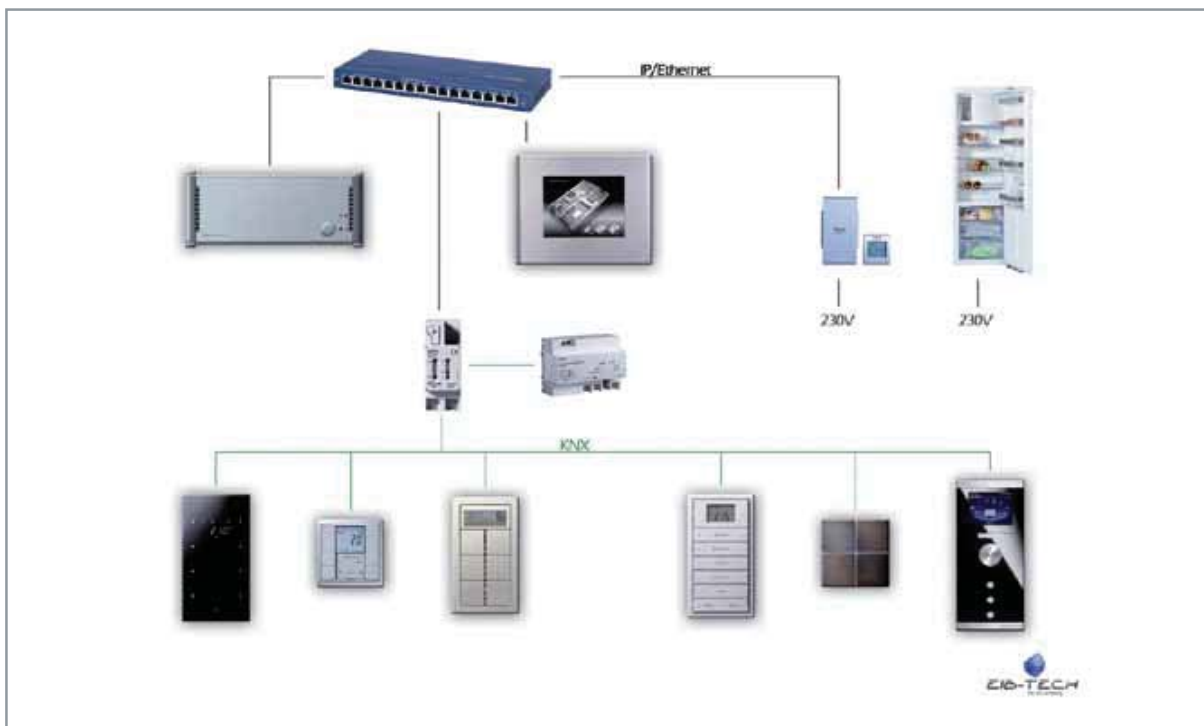

Fire Alarm Systems

Assignment

Fire alarm systems work independently. For easier maintenance, status information, information regarding system faults and triggered alarms these systems can be integrated into KNX systems. This helps to reduce false alarms and to improve fire fighting. InstaVer Systems from The Netherlands is very experienced with KNX installations in hotels, theatres, court buildings and police stations. Their demonstration shows how a fire alarm system can be integrated.

Solution

A NEN2535 certified fire alarm system constitutes the core of the installation. It contains an OPC server and communicates with the KNX bus via an “OPC-Bridge” application from NETxAUTOMATION.

Realisation

Reliability is the central requirement when integrating a fire alarm system into a KNX installation. For safe operation, visualisation of status and alarms has to be monitored. A KNX switch actuator with current detection (by ABB) and a temperature sensor (by Zennio), ensures this. They detect the input current and the internal temperature of the fire alarm panel. The system also checks whether the browser is still active. Faults are indicated both visually and via an acoustic signal.

The “OPC-Bridge” consists out of a rail-mounted OPC/KNX gateway (by TCI). Fulfilling a request from the fire brigade, additional KNX push buttons are installed to allow navigation within the

visualisation system. In addition to the features shown in the demo installation, status messages from the following functions/sub systems are often monitored in real-life projects: sprinkler systems, emergency messages from toilets for handicapped persons, overvoltage, network supervision, fire protection doors etc.

Functions:

Via the touch screen, status information about fire alarm notification appliances and smoke detectors can be displayed graphically. Several functions like: “Pre-alarm”, “Alarm” and “Test”, are shown.

If a smoke detector triggers an alarm, the following information is displayed: “Pre-alarm”

or “Alarm”, together with the indication of the floor where the alarm is coming from, the fastest way to the appliance giving the fire alarm notification, the escape routes and the access for the fire brigade. An audio file with emergency instructions is played.

And at the same time, the KNX system automatically controls the following important functions: granting access (e.g. opening cabinets), driving up blinds, shutting fire resistant doors, switching on lights and closing heating valves.

Advantages

- Faster diagnose for the causes of each triggered alarm
- Reduction of false alarms to the fire brigade
- Support for fire fighting and evacuation
- Easier maintenance for fire alarm systems
- Tests of fire alarm notification appliances are kept and the yearly rehearsal can be displayed upon request.
- As KNX covers all application fields, synergies are possible thanks to the multiple-usability of components, which makes KNX installations even more valuable.

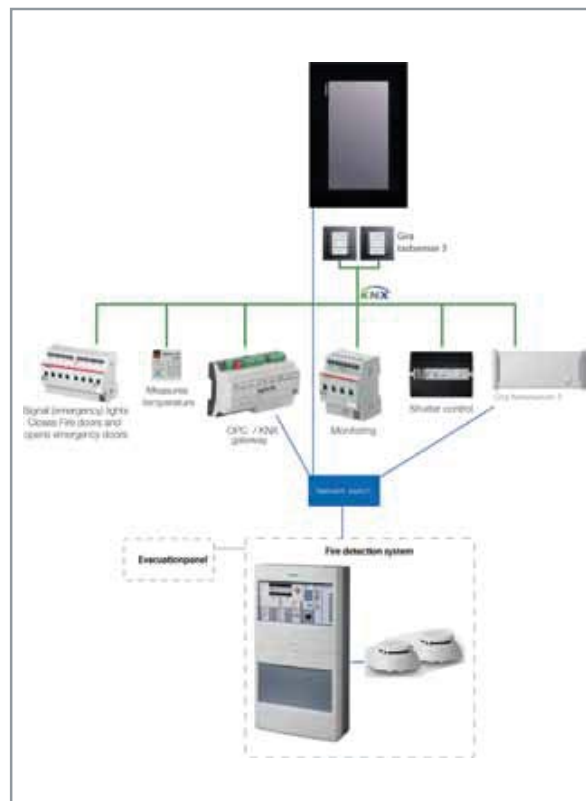

evizion
makes living smart

InstaVer Systems BV
Lireweg 90
2153 PH, Nieuw Vennepe
Niederlande
Tel.: +31 (252) 626633
Fax: +31 (252) 687664
E-Mail: info@instaver.nl
Web: www.evizion.nl

Gateways

Assignment

While KNX the basis is for home and building automation systems, proprietary systems are frequently used for dedicated functions. To realise a consistent building management system, it is important to integrate these dedicated functions into the KNX system too. Advantages: no duplicate installations and operating units, consistent user interfaces for all functions, operating units in tune with interior design requirements, central visualisation functions including error messages and alarm management.

Solution

To achieve this, either common gateways as they are available on the market or

special gateways for proprietary protocols can be used. The engineering company Holger Schult demonstrates

how common gateways can be used together with KNX. They have tried and tested all these solutions.

HSEEG
 HSEEG - Ingenieurbüro
 für Elektroplanung und
 Gebäudesystemtechnik
 Dipl.-Ing. Holger Schult
 Waidmannsweg 7
 16548 Glienicke
 Tel.: +49 33056 89632
 Fax.: +49 33056 89633
 Mail: info@hseg.eu



Function area	Manufacturer / Gateway	Operation and visualisation via KNX for	Functions
Lighting	MDT DALI/KNX gateway	DALI	Control and dimming of DALI lighting from any manufacturer
Escape Routes System	WAGO IPC with KNX/TPI terminator used as CAN Bus gateway	CANopen	Communication with GEZE escape door control
HVAC systems	Theben OT-Box	OpenTherm	Connects KNX to the OT Bus used for heating systems, e.g. gas condensing boilers
Metering data recording	bb-Steuerungstechnik M-Bus gateway	M-Bus	Reading M-Bus meters from any manufacturer
Operating data and error messages Recording for UPS systems (uninterruptible power supplies)	Genorex Modbus RTU	Modbus-RTU	UPS monitoring e.g. by Wöhrl
Electrical metering (current, voltage)	WAGO Controller with KNX/TPI terminal and RS485 serial interface	Modbus-RTU	Connection to Janitza and Socomec measurement instruments
Access controls systems		RS485	Integration of the BlueChip lock system by Winkhaus
EnOcean radio technology	Weinzierl Engineering EnOcean Gateway	EnOcean	Connects the wireless radio system with KNX, in this particular case the sensors were from Thermokon
Automatisierung mit Standard BACnet	WAGO Controller with KNX/TPI terminal	BACnet	All systems using the BACnet protocol, regardless of manufacturer
Ethernet	Siemens IP-Router	IP	Web Applications

IP Control

Task

The task scenario was the refurbishment of a commercial building (in this example, a bank). Applications include centralized and decentralized control of daylight-dependent lighting, temperature and volume flow with special focus on energy efficiency. Due to the large floor area of the tower block with a total of 18 floors (five sub-floors, one mezzanine, ground floor, 11 upper floors) and the high number of data points to be processed (approx. 30,000) the building had to be sub-divided into several KNX domains. Another aspect is the technical implementation of the customer's security requirements for certain areas.

Solution

Together with the designers, TAST Deutschland agreed on eight KNX domains which are connected with each other via glass fiber cables and media couplers. This created a KNXIP

backbone and sub-distribution lines, using additional line couplers for distributing the signals on the KNX system.

Implementation and functions

- Control of lighting in the public areas via buttons and central functions.
- Control of lighting in the offices with active constant light control.
- Decentralized individual room temperature control in all offices (Jung room controller) with target values provided by the building control system. Valves (Oventrop) for heating and cooling ceilings are fitted with analogue controls.
- Volume flow control in the offices in accordance with data provided by the building control system. The heating of rooms is controlled via the flow control mechanism (air intake and air exhaust in parallel).

- Central functions are enabled via coupling to the building control system (Desigo In-sight) as well as central KNX visualization.

Advantages

With the help of the sub-division into KNX domains and cross-linking via KNX IP networks, it was possible to create a very stable KNX system with reduced (optimized) bus load while at the same time improving stability and performance. With the help of the high number of presence and movement sensors, the KNX visualization and the building control system link it was possible to achieve additional reductions in operating costs. An added benefit is the fact that the sub-division allows parallel processing of the databases. The easy and economic installation of the KNX bus in two-wire technology, together with the almost unlimited technical possibilities for control of lighting,

blinds, heating, ventilation and air conditioning, is particularly advantageous. The field bus allows the transfer of large quantities of data; this meets the new requirements of bus systems used for the control and transmission of data for the purpose of energy and maintenance management.



TAST DEUTSCHLAND
Jens Hoffmann / Rainer Strauß
Milwitzweg 3
99097 Erfurt, Germany
Phone: +49 361 4171971
Fax: +49 361 4171972
Mail: info@tast-deutschland.de
www.tast-deutschland.de

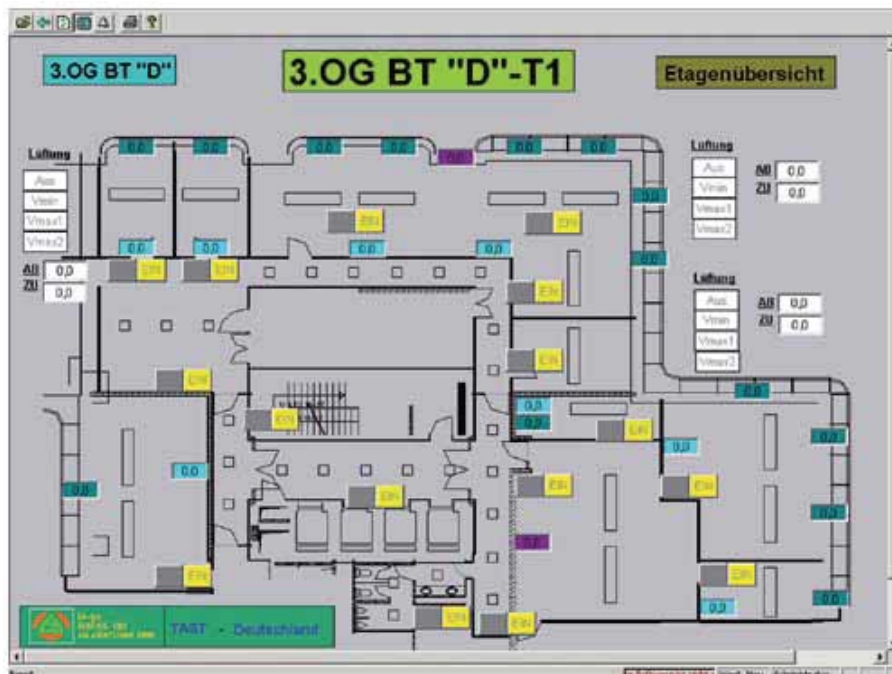

LED Control

Task

Modern LED technology allows for attractive lighting effects that can be used in shops, shop windows, lobbies, bars or in the home. This is a new task for KNX and system integrators. Color temperatures can be changed to create different kinds of mood lighting. The application demonstrates how LED lamps can be activated and controlled via special lighting control devices.

Solution:

Riwitec, an electrical installation company from Innsbruck, uses the new LED lighting technology for KNX by Bilton. KNX sensors and controlling devices, as well as LED strips, LED spots and spot lights for rails are used to demonstrate how easy it is to create lighting scenarios with LED lighting technology.

Implementation

The presentation will be realized with the following KNX components:

- The universal dimming and sequencing actuator for KNX (Bilton) is used as a direct interface to the LEDs for switching and dimming.
- A universal dimming and sequencing actuator for power LEDs in the range of 350/500/700mA (Bilton) is used as a second actuator. This device can activate individual colors as well as built-in RGB spots with LEDs.
- Also, we will show how the Nexus spot light for rails with an integrated KNX interface can be used to create mood lighting. Color temperatures in the range between 2800 K and 7000 K can be switched or dimmed with this device.
- A KNX presence detector (BEG) and a light sensor are used for automation purposes.

- The system (installed in a vertical board) is accessed and controlled either via a pushbutton (Gira) or via a Comfort-Panel (Busch-Jaeger).

Functions

Users can switch and dim the lighting via the touch panel of this comfortable device and select colors. Depending on the time of day, they can pre-set different colours and color temperatures for the Nexus spotlight. A presence detector is used to trigger different logic operations in order to change the colors when a person appears. Daylight brightness is also measured in order to achieve an optimum light intensity in interior rooms.

Advantages

KNX allows integration of LED lighting in a simple and intelligent way. There are solutions for numerous applications such as art galleries, museums, shops,

architecture and especially for residential and non-residential buildings. One example is the changing of color temperatures using simple LED strips. Users will feel comfortable in this environment, because the lighting system provides optimum color temperature, intensity and effects.



Rene Rieck
 Dorfstrasse 40
 6122 Fritzens, Austria
 Mail: r.rieck@knx-forum.at



Audio & Video Control

Task

The control of audio and visual media is an interesting task for KNX. In an 'intelligent' house, in which the electrical installation has already been carried out with bus technology, it is possible to activate music, news or video films in the respective rooms.

Solution

The optical highlight of a 'virtual' house should be a monitor for showing films or slides and playing videos etc. In order to show the function of a multi-room audio system, two rooms are simulated in which different media can be played. But it is also possible, in 'party' mode, to play the same music in all rooms. The system is centrally operated via different touch panels or via bus button in the individual rooms. In home installations, a TV set

or projector would be used as a display, which could also be controlled by the KNX system.

Implementation

A 17" touch screen element (AMX) is used to show films and videos. This can be operated via the KNX visualization, which can also be displayed. Another touch panel (Merten 7" KNX touch panel) is used as an operating unit for controlling the media as well as the general KNX system for lighting, heating control and solar screening. Two loudspeakers are used to simulate different rooms or audio zones. There are touch sensors for each different zone, indicating the compatibility with the KNX system. Content such as pictures, videos and music are stored in digital form in an audio/video media server and are activated via the KNX domain as well as

the AMX visualization domain. Audio output is controlled via the integrated Russound audio multi-room system. Both the AMX video components and the Russound multi-room audio components are perfectly integrated into the KNX system via KNX gateways.

Functions

The installation of the different touch displays with their respective surfaces shows the multiple options for operating equipment with respect to technology, design and operating comfort. The different brightness and volume controls, also available as a slide controller, demonstrate the variety of operating options. In addition it is possible to activate audio and video content or to adjust the volume via conventional buttons or KNX bus buttons.

Advantages

There is no need for additional control systems. The media controls are simply integrated into the KNX installation which is already in place, making this functional solution even more economical and visually appealing, as the operating elements match the other parts of the electrical installation. Interfaces for TV sets and media sources are readily available in the respective retail outlets.

cab-ih.com
intelligent home

CA Brachtendorf
GmbH & Co. KG
Clemens A. Brachtendorf,
Dipl.Ing.(FH)
Weiherstraße 10
40219 Düsseldorf, Germany
Phone: +49 211 5580527
Fax: +49 211 5580449
Mail: brachtendorf@cab-ih.com
http://Cab-ih.com

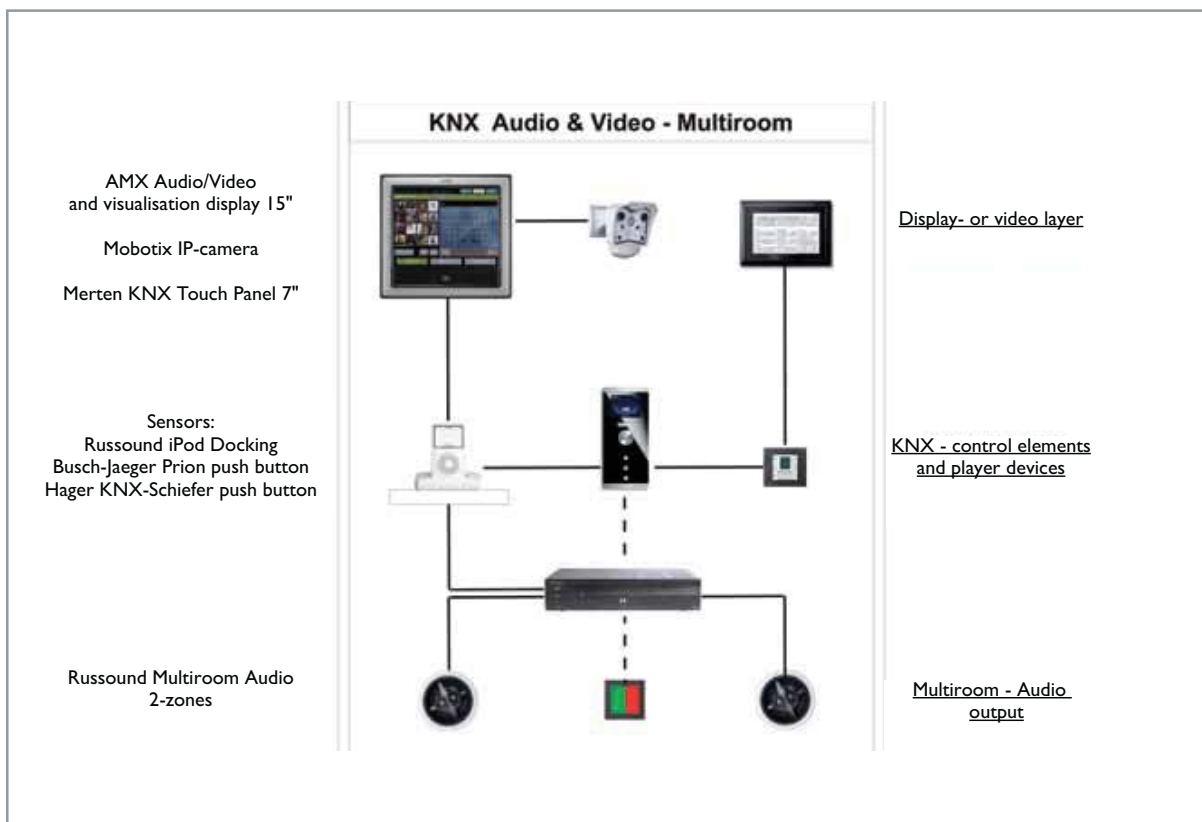

Telephone Control

Assignment

To control building automation systems, intelligent user interfaces are required. It is common practice to use separate systems for each functional area. GLT Planungsbüro für Gebäudetechnik shows how all functional areas can be integrated into one system, all with low integration and administration costs, while increasing performance and flexibility.

Solution

Members of staff use a client software in combination with their telephone in order to access the individually assigned building automation functions. This allows them to open or close blinds, change the room temperature or to switch and dim light. The client software can also be used as communication means in combination with a headset.

Realisation

The communication and automation solution CYTEL.WAVE accesses the KNX bus via a KNX IP gateway. Apart from the usual functions of an enterprise class telephone system, CYTEL.WAVE offers a high-performance automation service that can be freely configured via scripts. The system can be used to automate and control telephone and building functions.

The client software allows access: to building control and telephone functions, to surveillance cameras, to historical and energy consumption data, from any office workplace.

Additionally: building automation functions can be assigned to telephone buttons.

Features

- Access to all building automation functions including KNX via client software and telephone
- Efficient telephone system including chat function, voice mail, video telephony and fax
- Integration of surveillance cameras
- Flexible automation functions
- Extensive authorisation system: access rights can be assigned on the level of functions and group addresses
- Interfaces for IP, ISDN, GSM, SIP
- Log files are sent to an SQL server for later statistical analysis

Advantages

Complete control for room functions from operator desktop screens. Only one client software needed for building automation and communication functions. One central system controls communication and automation. User concepts are flexible and open for later modification. The software can be installed on various PCs. Significantly lower costs as only one system is needed.

GLTPLAN
Smart Buildings

GLT-Plan Planungsbüro
für Gebäudetechnik
Markus Schwarz,
Systemintegrator
Zum Seebühl 30
78315 Radolfzell
Tel.: 07732 / 9409408
Fax.: 07732 / 9409409
Mail: info@gltplan.de
Web: www.gltplan.de

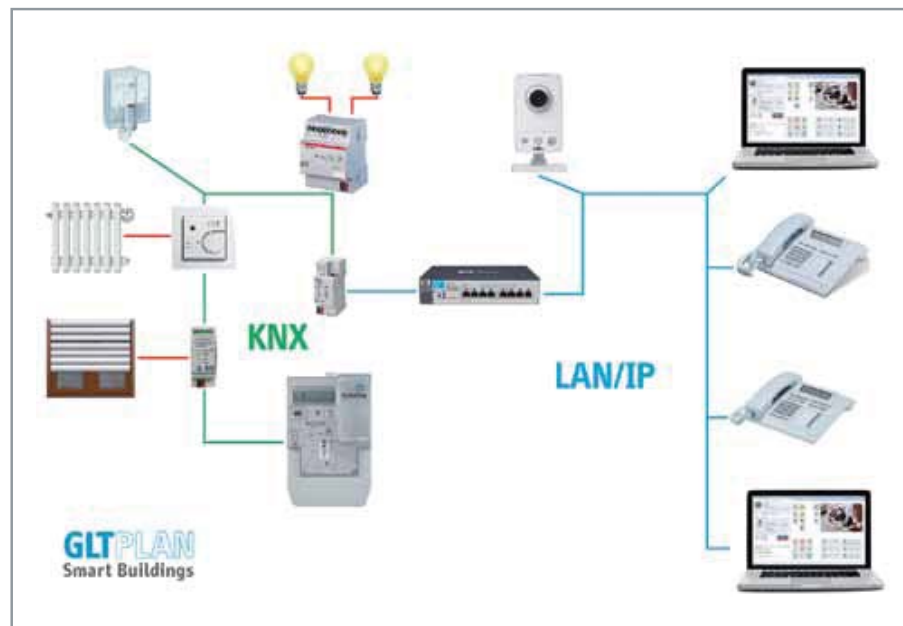

iPhone® Control

Task

Realization of a KNX control for iPhone, iPod Touch and iPad

Solution:

ibs intelligent building services gmbh presents a solution that uses standard KNX components for all home and building applications. The application is based on the m..remote visualisation software in connection with the new m..myhome server.

Implementation:

m..remote Client is a freely configurable visualization software for iPhone, iPod Touch and iPad. The GUIs can be created in a special editor and will then be loaded to the end device. Mobile devices communicate with the system

via a WLAN connection into the local cable-based network. Processing and communication with KNX installations is realised via the m..myhome controller. This technology uses KNX IP. The controller can handle up to 50 KNX addresses at a time. A variety of protocols can be adapted, therefore the system can also be used for complex media controls and allows integration of all internal functions available in the world of KNX. The built-in scripting engine makes it easy to initiate complex command sequences.

Functions

Users can access typical functions of advanced home and building automation (such

as lighting systems, heatings and blinds) via wall-mounted controls and mobile devices. Audio and video controls are also integrated. A touch panel is used as a central control, allowing access to KNX functions and to the world of digital media such as TV and audio. The integration of an iPod Touch as a fixed wall control will also be demonstrated. This solution is especially useful for hotels. The wireless integration offers both maximum flexibility and maximum functionality.

Advantages

The advantages of this solution are undisputed. Being a so-called native App, the m..remote visualisation offers speedy access times. This system helps to avoid typical

latency times that occur in web-based solutions. When integrating media technology, this is a decisive advantage. This solution offers an easy entry into the world of home and building automation at a truly competitive price. The system includes a 10" touch panel of the latest generation.

ibs intelligent building services gmbh
 INHOUSE Dortmund, Ebene 3
 Rosemeyerstrasse 14
 44139 Dortmund, Germany
 Phone: +49 (0) 231 476425-60
 Fax: +49 (0) 231 476425-89
 m.eudenbach@mac.com
<http://www.macmyhome.de>
<http://www.mremote.de> (im Aufbau)



WLAN Control

Task

Systems for media technology and building automation are becoming ever more complex. Installers are increasingly confronted with data processing tasks. A minimalist solution is called for, that allows users to create and monitor light and shadow without a “server”, using a simple remote control from their armchair. Also, they should be able to create lighting scenarios and to switch HVAC appliances or security functions. The possibility of ETS parameterization via WLAN is also a requirement.

Solution

Decentralization is a definite strength of the KNX bus: Without a central computer all home data such as switching status and temperatures are

available on the bus. This great feature of KNX was used in the development of freely configurable software for media remote control and enables server-less central control, monitoring and data recording.

Implementation

The image shows a remote control for media access that communicates with the bus via a WLAN router and the ProKNX gateway. The communication objects of the gateway are allocated to group addresses via ETS in the usual way. An editor is provided free of charge that allows the combination of the components used in a home via icons. Also, it allows for the configuration of media devices.

Functions

Apart from simple switching actions, users can set lighting scenarios and save them in the actuators according to the KNX specification. These scenarios can be combined with macros for the control of media technology, e.g. to shut the blinds or roller shutters and to dim the lights when a film starts.

There are controls for individual rooms, and operating statuses can be switched via integrated timers. Temperature and energy values are saved every hour and can be displayed as a linear chart for the past week.

Advantages

The configuration shown here can be used for an intuitive control of the entire house without any additional hard-

ware – the ProKNX gateway and a media remote control are all you need. You can easily integrate media devices and a variety of other components and control them via wireless access. Installers can create or retrofit KNX installations with this technology without knowledge of a programming language.



by BleuComm'Azur

Dipl. Ing. Univ Christian Kiefel
180, imp. du Baou
06560 Valbonne, France
Phone: +33 6 07 50 25 06
www.proknx.com



Social Networks

Assignment

Intelligent Buildings in Social Networks. The requirement is to automatically transmit system faults, alarms, video-intercom images and orders for different services via social networks.

Solution

A suitable gateway is needed in order to connect a KNX system with diverse social networks such as Facebook, Twitter and Prowl. This is where NOMOS Box, the new IBS product, comes into play. The new multi-protocol gateway/server is the first of its kind and supports up to 25 different protocols. It offers bidirectional access from and to KNX. Interoperability of the different protocols is ensured. Apart from the gateway functionality, the NOMOS Box also provides an HTML5 server that can be used to visualise data from different platforms.

Realisation

The panel shows basic functions of modern building automation systems: a room controller by Jung serves as a central operational control for presence-dependent functions, room temperature, lighting and service requests via social networks. A motion detector by Busch-Jaeger is used for presence detection and a webcam serves to monitor the room. Actuators and an IP router (by Siemens and ABB) are the system components used here. Various Apple products are used to control the devices and to visualise data. They are connected to the HTML5 server via a Wifi network. A 15" display is used to show the application's Facebook account. The NOMOS Box as central device evaluates all KNX events and transmits messages to social networks where appropriate.

Features

The primary use of this system is to show the possibilities of social networks in combination with smart buildings. For example beverages can be ordered at the supplier with a simple push of a button. Alarms are transmitted together with an up-to-date camera image, if a motion detector triggers an event when the owners are not at home. Also current metering data is transmitted via the social network.

Advantages

The use of social networks offers many advantages: these services are free of charge and allow users to manage the transmission of data and the access to systems. There are client applications available for nearly all platform that allow users to access social networks. If a residential building has its own Facebook account, a kind

of data diary can be kept: How much energy did my house consume? Who rang at what time the doorbell? What kind of malfunctions occurred during a particular period in time?

Persons who need assistance can make their data available to a group of people they trust. This even allows the integration of several types of services.

 **ibs**
intelligent building services gmbh
Michael Eudenbach
Rosemeyerstr. 14
44139 Dortmund
Tel.: +49 231 476 425 60
E-Mail: m.eudenbach@mac.com



Scenarios in a holiday paradise

Comfort and efficiency by coupling KNX with the hotel management system



Stylish waterfall: To prevent a gust of wind from blowing the water in the wrong direction, a KNX weather station switches off the pump when the wind is too strong.

“La Marquise” on the Greek holiday island of Rhodes shows how economic and convenient hotel management can be implemented with KNX. The luxury resort spanning an area of 12 hectares looks like a stylish hotel village with bungalows, green areas and pools. The buildings with luxury rooms, suites, restaurants, bars etc. are fitted with highly modern building technology. The guests already profit from it on arrival: the key card not only opens the door but also activates a room scenario for lighting, air conditioning, TV, hot water, alarm management and information. The KNX installation, which was built by Prousaloglou Pantelis-Konstantinos & SIA OE was presented with the International Award for Europe and supports comfort, security, hotel service and energy efficiency through applications for lighting, sun protection, air conditioning, audio/video, alarm systems and monitoring.

Energy management reduces load peaks

Working together with the hotel management, the system integrator has implemented numerous functions for the well-being and safety of the guests, for energy efficiency and for the smooth operation of the hotel. The interaction of the hotel management system and KNX was developed with IPAS GmbH. The guests can combine their favourite lighting, climate and media entertainment themselves and store them as individual scenes. The key card provides the hotel service with important information, for example when the room is occupied, when it can be cleaned or when guests do not want to be disturbed. If the card holder signals that the room is empty, the lights are switched off and air conditioning devices are switched from comfort to economy mode. Pre-programmed light scenes are also available in public areas such as the lobby, the bar or the dining room, as well as the

outside areas. Depending on time programs, brightness and hotel management, the light scenes create light moods, ensure safety on the paths and illuminate the architecture. The media control for music in all areas is controlled via KNX audio actuators.

Energy efficiency is an important topic: the fan coil controllers are interlocked with door and window contacts to prevent energy loss. An energy management system for cooling devices, heat pumps and household appliances helps to save gas, water and electricity and prevents peak loads from being exceeded. If emergency power is activated via a generator, an intelligent logic distinguishes between loads that are important for operation and those that are less important and switches them on or off accordingly. Fault signals and technical monitoring are likewise based on KNX. The display is carried out via a visualisation on the workstation PC or on the move using a tablet PC or mobile phone.

The comprehensive topology was implemented with IP routers and fibre optic technology.

Some details of the project: 8,934 devices and 47,720 group addresses with 124,179 address assignments.

Benefits provided by KNX in this project

- Demand-based control for more efficient energy use
- Increased comfort for the guests
- Improved service
- Safety using alarm scenarios
- Energy management
- Simplified control and operation
- Decentralised remote maintenance from any stationary and mobile PC
- Flexibility for modifications
- Staff workload is reduced

Technical refinements

- Coupling with the hotel management system
- All different kinds of scenarios for lighting, air conditioning, emergency operation, security etc.
- Control of the complete audio system
- Doubling of the possible group addresses through second ETS3 project

Companies involved

Building owner

AETEK.AE – Hotel „La Marquise“, Rhodes, Greece

Architect

Afoi Chatzikonstantinou OE & Neos Rythmos, Rhodes

Electrical Engineers

Prousaloglou Pantelis-Konstantinos & SIA O.E, Smart Building Solutions, Rhodes

Mechanical engineer

V & D Varouxakis, Ionia, Athens

System integrator

Prousaloglou Pantelis

Area of application

Hotel

Functions

- Lighting
- Heating, ventilation, air conditioning
- Alarm systems
- Technical monitoring
- Energy management
- Audio/video
- Visualisation
- Interfaces to other systems
- Remote monitoring/control

Scope

Number of KNX devices: 8934, Siemens, IPAS GmbH etc.

An example for energy efficiency in Southern Europe

At the Metal Foundation in the Spanish city of Avilés (Asturias), KNX controls and regulates the lighting, sun protection and air conditioning



With its energy-efficient building technology, the headquarters of the foundation have the chance to become one of the first NZEB (Near Zero Energy Buildings) in Spain

The Metal Foundation in Asturias on the Costa Verde is one of the first educational establishments to offer KNX training in Spain. It is only logical that the new headquarters of the charitable foundation in Avilés should be fitted with the bus system. Since its opening in 2012, training rooms and laboratories are housed on the 3,000 square metres of floor space. The versatility of KNX for efficiency, comfort, security and control should be illustrated by the building automation system. The building technology emphasises the foundation's commitment to new technologies for sustainability and environmental protection. The project was supported by industry partners both in an advisory and physical capacity. The engineering office DOERCO in Gijón was presented with the KNX Award International Award for Europe for its successful system integration.

The 150 lighting circuits of the interior lighting are controlled via KNX. Constant lighting controllers which take into account the level of daylight are implemented in rooms with large windows and they are therefore extremely efficient. Presence detectors also provide economic lighting on demand. In spite of this, it is possible to switch the light on manually via a push button when it is economically reasonable. An astro time switch ensures that the exterior lighting is automatically switched on at dusk, is switched off during the night and then switched on again at dawn. The blinds in front of the training rooms and offices are used for anti-glare protection and support the energy efficiency of the building. They keep the building cool in the summer and let the sun's warmth into the rooms during the winter. This intelligent control is based on a Heliometric software and receives the data from weather stations,

such as brightness and wind force, room temperature, presence signals, sun position and points of the compass. Even the louvre angles are set automatically.

The KNX individual room controller also saves energy whether it is for heating or cooling. The setpoint values, whether comfort or standby, are set independently of the layout. The interlocking of the control circuits with window contacts prevents loss of heat or cold. KNX communicates with the HVAC system to adapt the generation of heat or cold to the requirements of the room. The KNX terminal of a Wago IP controller is used as an interface and integrates other systems such as BACnet, MOD-BUS, DALI and Enocean.

With the KNX intruder alarm system, signals from presence detectors and window contacts are used to trigger the alarm and activate the surveillance cameras. An energy management system, which is organised via an "eibPort" module, processes consumption data. The interface to the BMS increases the level of security in the event of an alarm and technical monitoring supports the system maintenance. Fault signals can be sent via email. Four touch screens are installed for the central control and operation of the KNX functions. There is also a central control point with a visualisation screen from which you can access the entire building technology.

Benefits provided by KNX in this project

- Energy-saving control of the lighting systems
- Efficient and convenient individual room control
- Sun protection supports the ambience in the room
- Energy management
- Central control
- Technical monitoring
- Visual perception of advanced KNX training
- Flexible for optimisation and changes in use

Technical refinements

- Constant lighting control for room lighting
- Preventative and corrective maintenance through current detection
- Temperature control communicates with the HVAC system
- Wago IP controller as interface between KNX and other systems
- Blind control dependent on meteorological data and solar position
- Fault signals via email

Companies involved

Building owner, Planning
Fundación Metal Asturias, Avilés
(www.fundacionmetal.org)

KNX System Integrator
KNX system integration:
Doerco Ingeniería, Gijón,
(www.doerco.com)

Area of application

Educational institution

Functions

- Lighting
- HVAC
- Shading
- Alarm systems
- Technical monitoring
- Energy management
- Visualisation
- Interfaces

Scope

Number of KNX devices: 340, ABB, b.a.b.-technologie GmbH, Jung, Schneider, Siemens, Somfy, Mobotix, Wago etc.

Costs

330.000 euros

Excellent study atmosphere in desert campus

In Saudi Arabia's university for women, building system technology controlled by KNX enables the university to operate efficiently



The campus of the Princess Noura University for Women is impressive due to its size, architecture, comprehensive teaching programme, social facilities – and due to its highly modern building system technology

The Princess Noura Bint Abdul Rahman University in Riyadh, Saudi Arabia is the largest and probably the most modern university for women in the world. The teaching and research establishment incorporates faculties for health, humanities, art, languages, geography, history and Islamic studies. The campus covers 800 hectares and has been conceived as an independent district. It has space for 40,000 female students and 12,000 employees and includes a library, a university clinic, research centres, halls of residence, social facilities such as kindergartens, schools, mosques and even its own automatic rail system. The installation with its impressive and stylish architecture began operations in 2012.

The best features of the complex can also be seen in the building system technology. The KNX building system technology ensures efficient lighting and air conditioning and provides protection against sun and heat in all the university buildings. The system integrator of the extensive KNX installation, "Modern Times Technical

Systems (MTTS)", was presented with the International Award for Asia for this project.

Sun protection supports the air conditioning

Strong sunlight and temperatures over 45 degrees Celsius – as is usual in desert regions – require reliable sun protection or shading technology for the large glass fronts of the building. A comfortable atmosphere in the lecture halls, seminar rooms, offices and in areas such as the library and cafeteria is a prerequisite for the efficient operation of the university. Thousands of blinds not only protect against glare but also prevent the high levels of solar heat from penetrating the building. The blind drive mechanisms on all four facades of the building are controlled via a KNX weather station (Somfy AS-513) dependent on the current position and intensity of the sun. The option to set the blind and the louvre positions manually via a bus push button meets any individual requirements. These settings are reset to automatic mode via presence detectors when people leave the room.

The air conditioning is made more efficient by the sun protection which is an important factor for operating costs and environmental protection.

Partition control divides room functions

The bus installation for the lighting control in the 3- to 4-storey university buildings is divided into zones, with a distribution of the corresponding switch actuators, dimming actuators and other KNX devices. Presence-dependent and daylight-dependent controllers or constant lighting controllers ensure efficient lighting in classrooms, laboratories, offices, toilets etc. Manual operation is possible via bus push buttons. During presentations in the lecture halls and classrooms for example, it is possible to simply call up brightness values for the lighting and to set the darkness level via scene buttons (bus push button or media control). The technical refinements of the system include intelligent partition wall controllers. If the large lecture rooms are divided into two rooms, the room functions for lighting, shading and operation are automatically divided into two independent units.

KNX MT-701 panels are used for local central operation such as emergency lighting functions. They also make logic, time switch and scene functions available. A visualisation of the central operation, monitoring and control of the entire KNX installation was implemented with the NETxAutomation software. KNX is also able to communicate with the campus management system via a KNX BACnet gateway. The presence status in the individual rooms is used for occupant-dependent setpoint adjustment of the

climate control – a further contribution to increase building efficiency which is a mandatory requirement for the Princess Noura University due to the LEED standards (Leadership in Energy and Environmental Design).

Benefits provided by KNX in this project

- Sophisticated sun protection systems
- Energy-efficient lighting control
- Support for the air conditioning
- Automation with individual possibilities for operation
- Convenient scene control
- Central monitoring, operation and optimisation
- Flexible system for changes and extensions

Technical refinements

- Automatic shading with option of manual operation
- Presence-dependent and daylight-dependent lighting control
- Constant lighting control
- Retrievable scenes for projection mode
- Automatic partition wall control
- Communication with campus management
- Interfaces to BMS and to AMX media control

Companies involved

Services Engineers, Electrical Engineers, KNX System Integrator
Modern Times Technical Systems (MTTS),
www.mtts.com

Area of application

University

Functions

Lighting, Sun protection system, Heating, ventilation, air conditioning, Technical monitoring, Energy management, Audio /video, Visualisation, Interfaces

Scope

Number of KNX devices: 6550, ABB, Gira, Somfy etc.

Costs

3,200,000 US dollars

Highest level of efficiency for Singapore's skyline

In the twin-tower development Asia Square, KNX supports climate protection, comfort, safety and technical service



The towers are over 220 metres high and were presented with the coveted Green Mark Platinum Award

Singapore's skyline continues to grow not only in height but also in the number of skyscrapers. Amongst the newest of those completed are the Asia Square Twin Towers near the Marina Bay financial centre. On the 43-46 floors, there is a luxurious 280 room hotel, 190,000 square metre office space, an extensive sales floor for boutiques and a public podium for cultural events. Global companies such as Citi Bank, Julius Bär, Bank Sarasin, Lloyds, Google, Marsh and McLennan Companies amongst others have moved in here. The two Towers I + II are currently among the 10 highest in the metropolis. The buildings received the highest accolade with the Green Mark Platinum Award, a coveted title for environmental and sustainable building. One of the priorities was the production of solar electricity and biodiesel as well as water efficiency. Energy-saving building system technology

has also an important role. The KNX control solutions integrated by Yumetronics Pte Ltd in the lighting, technical monitoring and energy management functions have therefore earned the International Award for Asia according to the KNX jury.

Tenants can create their own switching programs

Over 90 percent of the lighting in the buildings is efficiently controlled via KNX. Presence detectors, brightness sensors, timer programs and schedules ensure that lighting circuits are only switched on when they are required and are dimmed down during daylight – without any loss of comfort or convenience.

The level of safety is also increased by the KNX applications. The presence signals from the staircase area are therefore used for monitoring in connection with the IBMS. The coupling also enables the lighting in the escape and evacuation routes to be switched

on fully automatically in the event of a fire. All the KNX functions can be supervised from a central location via the "Lighting Control and Management System" (LCMS) developed by Yumetronics. The recording of the operating hours of the luminaires and the evaluation of loads contribute to rapid servicing, efficient building maintenance and optimisation of the energy consumption.

The visualisation (ABB) also offers individual users the option of creating their own switching programs using access rights e.g. according to working hours, occupancy etc. Remote control via the internet is also possible.

Coupling the lift control with an authorisation card is one of the technical refinements. It also activates the lighting on the floor on which the lift arrives. All the parties involved in the project profit from the KNX installation, since planning security and system flexibility were key factors at the project design stage. The LCMS saves the building owner and the tenants energy and labour costs. Control functions can simply be adapted when the room use changes while the guests and employees enjoy comfortable lighting conditions. To meet personal preferences and to adapt when the working day is extended, room functions can simply be operated manually, even directly on the workstation PC. Prewarning functions such as the lights flashing prevent the building from being plunged into sudden darkness when there is a master reset. The climate protection also profits from the reduction in the carbon footprint due to lower energy consumption and no longer burning time of the luminaire.

Benefits provided by KNX in this project

- Versatile functionality, large number of components
- Flexible for optimisation and modifications
- Energy-efficient lighting
- High technical comfort
- Access rights for tenants
- Central technical monitoring
- Multiple use of the presence signals
- Security through coupling with the BMS
- Supports economic efficiency and sustainability

Technical refinements

- "Light Control and Management System" (LCMS)
- Supports systems such as DALI or 1-10V
- Monitoring of luminaires and operating hours
- Access rights for tenants
- Coupling with IBMS and emergency lighting
- Prewarning in event of a master reset

Companies involved

Building owner
MGPA, www.mgpa.com
Electrical Engineers and KNX System Integrator
Yumetronics Pte Ltd,
Stanley Yeo, Singapore

Area of application

Hotels, offices, retail, culture

Functions

- Lighting
- Technical monitoring
- Energy management
- Visualisation
- Interfaces to other systems
- Remote monitoring/control

Scope

Number of KNX devices: 4200, ABB, Theben etc.

Costs

2,500,000 US dollars

Pioneering building system technology on Australia's famous Surf Coast

KNX integrates all the functions for efficient control and central energy management



Environmental protection and sustainability are valued highly on the Surf Coast. The efficient building system technology with KNX meets this requirement

With its spectacular scenery and ideal surfing conditions, the Surf Coast in Victoria, Australia attracts tourists from all over the world with its nature reserves. The "Surf Coast Civic Building" began operations in 2011 in the small township of Torquay at the gateway to the Great Ocean Road. It is a modern community centre for sport, culture and communication. During the implementation, the builder Surf Coast Shire Council placed great importance on environmental protection and energy efficiency. This is also shown in the building system technology which is controlled efficiently via KNX. The integration of a wide variety of functions in a central system is a new

and innovative idea for Australia – this was one of the reasons that the system integrator Peter Garrett of mySmart CTI decided on the versatile global standard. It is not only possible to control all the lighting and monitoring functions, as well as, the energy and water consumption via a 40" LCD display in the building foyer but also to visualise the energy gains of the wind power and photovoltaic systems which belong to the complex. This presentation has public appeal and emphasises the environmentally friendly building concept. The impressive KNX installation was presented with the International Award for Africa, America and Australia.



Building blocks for the Green Building certificate

mySmart CTI integrated all the features of KNX in order to implement the efficient lighting control system including lighting sensors and dimmers which ensure a consistent level of brightness with optimum use of daylight, presence detectors provide lighting according to demand. The floodlights on the playing field are switched on and off via brightness sensors depending on the time that they are used. Unnecessary burn times are thereby avoided.

KNX push buttons and controllers also ensure that convenient manual operation can be carried out.

Ventilation systems and individual heating devices can also be controlled via KNX, partly automatically and partly manually. They can thus be included in the central control system. The following functions are integrated in the energy management system: lighting control, shutters and blinds control, energy monitoring, consumption display and smart metering for renewable energy. To achieve the highest possible level of efficiency, hydraulic systems such as rain water pumps and solar hot water pumps are monitored, flow rates are measured and temperatures are controlled via KNX.

The interface to the AMX media technology is one of the highlights of the installation. By coupling the audio and video system with the KNX lighting control, relevant lightscenes can be called up during events. These scenes can be created individually by the user via the visualisation system. A 42" LCD display has been installed in the foyer for the public display of the energy currents and analy-

Benefits provided by KNX in this project

- Energy-efficient control of the building technology
- Integration of all functions for central management
- Smart metering for energy loads, water consumption and regenerative energy sources
- Presentation of loads and energy gain via a 40" LCD display
- Monitoring and fault signals
- Remote access for service and maintenance

Technical refinements

- Merging of different functions for central management
- Coupling of the media control with retrieval of lightscenes
- Arming of the security technology triggers lighting functions

Companies involved

Building owner

Surf Coast Shire Council, Torquay, Australia

KNX System Integrator

Peter Garrett, mySmartCTI, North Ryde, Australia

Area of application

Public building

Functions

- Lighting
- Heating, ventilation
- Technical monitoring
- Energy management
- Audio/video
- Visualisation
- Interfaces to other systems
- Remote monitoring/control

Scope

Number of KNX devices: 279, ABB, Hager etc.

Costs

130,000 Australian dollars

sis. The central management is based on the NETxAutomation Voyager software which also enables remote servicing on the PC. Last and by no means least, is the KNX technology which controls the building efficiently and has contributed to its certification as a 5-star Green Building. At mySmart CTI, they are proud to have been instrumental in building this world class facility.

Intelligence of stellar architecture

Integrated into a sustainable building concept with KNX modules



Freely definable KNX light scenes contribute to the success of the events held in the 2500 square metre atrium.

High levels of daylight, glass building materials and an imposing architectural design from the star architects "Ingehoven Architects" characterise the new headquarters of the HDI Gerling property insurance group in Hannover. Spread over five floors and covering an area of 75,000 square metres, 2000 employees have a modern, ecological and ergonomic place to work. The sustainable building concept is guided by the DGNB gold standard and links minimum consumption of energy and resources with greater convenience of use. In addition to triple glazing, thermal insulation and the production of regenerative energy, the lighting and blinds controlled by KNX is an important part of the energy efficiency throughout the system. The company charged with the project implementation, Bauer Elektroanlagen GmbH Halle, was presented with the KNX National Award for Germany for this unusual project.

Sun protection designed using a model

The blind control in building complexes is very important. Possible wind influences, seasonal positions of the sun, shadows, reflections and thermal discharge have therefore already been simulated and calculated during the planning phase using a model. A complex blind control system was developed on this basis with KNX, SMI and Ventus Digisonic sun protection. The shading functions depend on a time program, solar radiation, shadows and wind strength. 70 wind monitoring points have been installed to take into account different wind conditions of the facades. Finally, the automatic louvre adjustment guarantees optimum use of external brightness. The employees are also able to operate their blinds themselves via bus push buttons.

The presence- and brightness-dependent lighting control via KNX and DALI is also efficient. The high level of flexibility of the lighting installation is impressive, whereby each of

the 3000 lights has its own presence detector. The light sources can be easily assigned with the specially developed Codesys program when there are changes in use. Bus push buttons have been equipped with the flexible system Gira ITS30. Smart sensors, which match the décor, control the ceiling cooling fans.

The lighting in the corridors, staircases, underground car parks and outdoor areas is also controlled automatically. In the conference area, scenarios with blackout, lighting and projectors can be called up via the media technology. By coupling the intruder and fire alarm system, the lighting is automatically switched on and blinds are raised in the event of an alarm.

KNX panels have been installed in areas where operating functions are more frequent, such as the restaurant, the canteen, the kitchen and conference rooms. Important KNX functions are monitored, controlled and influenced via a central building management software. To do so, 4,500 data points have been processed via the KNX OPC server NetX-Automation. The topology of the KNX installation is organised via Wago KNX IP controllers which also provide interfaces to other systems with corresponding "terminals".

Benefits provided by KNX in this project

- Increased energy efficiency through intelligent functions
- Comfortable working conditions due to optimum shading
- Individual operation of lights and blinds in the offices
- Central functions for lighting, sun protection and room temperature
- Light moods for events thanks to scene control
- Consistent and uniform installation
- Flexible for changes in use

Technical refinements

- Complex blind control according to time, solar radiation, shadows and wind strength
- Constant lighting control for efficient lighting
- High level of flexibility due to presence detection per lamp
- Special supplementary program for assignment of the lights
- Coupling of intruder and fire alarm systems
- Coupling with the BMS

Companies involved

Building owner

Ampega Gerling, Hannover
(www.ampegagerling.de)

Architect

Ingehoven Architects,
Düsseldorf,
(www.ingehovenarchitects.com)

Electrical installer and KNX System Integrator

Bauer Elektroanlagen GmbH
Halle (www.bauer-netz.de)

Area of application

Administration building

Functions

- Lighting
- Sun protection
- Cooling
- Alarm systems
- Technical monitoring
- Energy management
- Media technology
- Visualisation
- Interfaces to other systems

Scope

Number of KNX devices: 1793,
Gira, Siemens, etc.

Costs

800,000 euros

Factory recycles waste heat from production

KNX automates ventilation, lighting and heating in industrial company



The new factory has production plants, warehouses and offices on its 5700 square metres site.

An industrial installation by Anton Hieber GmbH & Co Elektroanlagen AG shows how a ventilation system can be controlled efficiently with KNX in addition to the usual functions. At Ritter GmbH in Schwabmünchen, a manufacturer of plastic cartridge systems, considerable levels of waste heat accumulate when producing the castings. Ventilation functions in the new factory building are controlled via KNX, so that the room remains pleasantly cool in the summer while the residual heat helps to heat the room in the winter. The presence- and daylight-dependent lighting control is also efficient. The energy saving achieved and the short-term return of investment were amongst the factors which impressed the KNX jury for the National Award for Germany.

The production in the new

factory runs 306 days a year round the clock. So that the lighting need not to always be switched on at full brightness with over 600 fluorescent lamps, KNX automatically regulates the light intensity in connection with DALI. Presence detectors keep watch simultaneously, so that the light is only switched on when people are present. A saving effect of up to 70 percent is achieved. The sophisticated ventilation control brings further savings and even an energy gain. Ventilation flaps in the skylights – exterior and interior flaps – as well as openings for additional air in the side windows are opened and closed dependent on the temperature. While the extracted air is discharged over large areas during the summer, the ventilation in the winter is limited to the smaller interior flaps. This prevents the building from cooling down rapidly. The

KNX control of the ventilation flaps communicates with the fire alarm system so that they open automatically as a flue in the event of a fire. Finally, a weather station monitors the flap control and protects against rain and storms.

The waste heat of the production plants incurs heat gain: KNX temperature controllers control the heat removal so that it is either conducted over the roof or inside. The heating system itself, consisting of dark emitters, is controlled fully automatically via KNX.

A facility server with a corresponding 3D visualisation acts as a control point. Remote access using a smart phone or tablet PC is thus also possible. The server collects all the KNX fault signals, for example from the transformer station, compensation system, overvoltage monitoring, lifting system, air pressure monitoring etc. and relays important signals. Consumption values are also evaluated here.

The automated suction of ozone from the printing machines and harmful gases from the washing plant are among the technical refinements of the KNX system.

The system integrator points to a significantly smaller energy footprint: “Due to the temperature-dependent ventilation and use of waste heat, the use of fossil fuels can almost completely be avoided.” Including the lighting and the ventilation, this means around 280 tonnes less CO₂ or 50,310 euros lower operating costs per year.

Benefits provided by KNX in this project

- Economical and comfortable lighting (savings up to 70%)
- Good indoor climate due to temperature-controlled ventilation
- Low heating costs through heat gain in the winter
- Central visualisation in a clear 3D environment
- Users can set parameters and setpoint values themselves
- Technical fault signals and central monitoring
- Remote operation via Internet

Technical refinements

- Complex control for electrically operated ventilation flaps and windows
- Control of the waste heat from industrial production
- Technical monitoring with integration of fault signals from the energy supply and production plants
- Integrated emergency lighting

Companies involved

Building owner

Ritter GmbH, Schwabmünchen, www.ritter-online.de

Planning

Hermann Wiedemann, Ritter GmbH

Electrical Engineers, KNX System Integrator

Anton Hieber GmbH & Co Elektroanlagen KG, Schwabmünchen, www.elektrohieber.de

Area of application

Industry

Functions

- Lighting
- Heating, ventilation
- Technical monitoring
- Energy management
- Visualisation
- Interfaces
- Remote monitoring/control

Scope

Number of KNX devices: 120, ABB, Arcus-eds, Gira, Merten, Siemens, Theben

Costs

600,000 euros

KNX competence for Finland

Members of the KNX national group successfully stand up for information and training



The association of Finnish electrical installers STUL organises KNX basic courses for the electrical trade.

With the award “KNX introduction in a new country”, three KNX project applicants shared the prize for the successful launch of the KNX system in Finland: Tampereen Ammattikorkeakoulu, Sähkö-ja teleurakoitsijaliitto and STUL ry/KNX Finland ry. The submitted project describes how Finland has been introduced to KNX applications through seminars, training courses, exhibitions and conferences. These activities were the basis for developing the KNX market in this Scandinavian country. The targeted activities were presented with the Publicity Award by the KNX jury.

Impetus for the building automation market

When the National Group of Finland was founded in 2008, the companies Tampereen Ammattikorkeakoulu, Sähkö-ja teleurakoitsijaliitto and STUL ry/KNX Finland ry were involved. At that time, there was no official KNX training centre or competent

KNX experts in Finland and certainly no market for KNX components. The system for home and building automation was generally unknown. Those that did choose this worldwide, standardised building automation system were directed to training courses abroad in another language or had to teach themselves about the installation of KNX system and ETS.

Finnish electrical installers should have the opportunity to earn the KNX partner certification in their own language. The group set the following goals under the coordination of tutor Veijo Piikkilä: publishing the KNX handbook in Finnish, founding certified training schools and training Finnish certified KNX tutors. Collaboration with the association of Finnish electrical installers was also sought and proved to be very successful. Their commitment has paid off: by the end of 2011, 600 handbooks were sold in Finnish and 16 basic courses had been held. More than 100

Companies involved

Tampereen Ammattikorkeakoulu, Sähkö-ja teleurakoitsijaliitto STUL ry/KNX Finland ry.

graduates were able to receive their certificate. Meanwhile there are seven trained KNX tutors and three KNX schools on offer. At a nationwide tour across Finland with a KNX introduction and trade fair appearances, there were over 300 participants. There is also basic information available in Finnish. An increase in activities is requested and the National Group of Finland has therefore set further goals for 2012. As a consequence of the development of competence in the market, people and companies involved, can count on a strong impetus across the entire supply chain of building automation, from manufacturers and suppliers of KNX products, to planning engineers and electrical installations to service organisations.



Training courses in the Tamk training centre

Together with KNX on an eco journey

Intelligent functions make motor yacht comfortable and safe



Proficient on the high seas. Stainless steel designer push buttons in the cockpit while the actuator technology is protected in the distribution board in the hull

KNX gives you many good ideas. Why not enhance the sophisticated technology of a yacht with KNX electrical installation? Many high-quality components in terms of functionality and design are available. At eibmarkt.com GmbH, they considered this idea and automated the electrotechnology of a sports yacht with KNX and integrated many new functions for increased comfort and safety. After two years of planning and eight months of system integration, the global standard became fit for the high seas. After all, harsh conditions such as salty air, vibrations, humidity, heat and cold also had to be taken into account. This extraordinary project with the apt name of "Konnexa 42" impressed the jury and was presented with the KNX Special Award.

Nautical data on the touch screen

In the evening, the lights switch on automatically. Light scenes ensure an atmospheric ambience which is appropriate on a luxury yacht. In night mode, discretely placed LED luminaires show the safe route to the bathroom or the deck. They are automatically switched on and off by presence sensors on the floor area. In addition to the usual functions, such as lighting, room temperature control, media control, monitoring functions and load management, great importance was placed on small details. Automatic blackout and cleaning detection are integrated in the touch panel which prevents disruptive brightness and bad operation. Signals which are of vital significance, such as water ingress, are reported throughout the ship via voice output. Load management distinguishes between electricity from onshore or from the onboard battery and controls

the load accordingly in full mode or economy mode. A particular feature is a specially developed interface between KNX and the onboard electronics NMEA and the machine protocol CAN bus. This enables all the nautical ship data to be visualised and evaluated via the KNX server. Faults and operating states are detected quickly. This includes sophisticated functions such as the weather display or storm warnings with a wake-up function which make life on board comfortable and safe. The determination of the speed for an environmentally friendly boat trip is calculated by the KNX server using existing data about the engine and its consumption and is also dependent on wind, waves and loads. A monitor from Pro Face, with Elvis visualisation software, has been certified for use on yacht functions as a control unit. Presence detectors take on multiple functions for lighting control and the alarm system. Internet, music control, fault signals are integrated, as well as smoke detectors and water sensors. Large push buttons and the versatile room controller from Jung in stainless steel were chosen for the operation. Actuators with current detection supply data for the load management. 91 KNX devices in total are installed whose function has been accepted by the SeeBG (ship safety). The "Konnexa 42" project is currently an approved exhibition and training yacht which can inspire both imitators and interested yacht owners.

Benefits provided by KNX in this project

- Central visualisation of all the functions of KNX and onboard electronics
- Scene control for LED effect lighting
- Time programs
- Energy and load management
- Economical calculation of boat trips via the KNX server
- Voice output and voice control
- Smoke detector monitoring
- Leakage monitoring
- Window and door monitoring
- Operating, fault and alarm signals
- Weather station for weather warnings
- Remote maintenance

Technical refinements

- Interface to onboard electronics and machine protocol

Companies involved

KNX System Integrator
Marco Labahn, eibmarkt.com GmbH, Plauen

Area of application

Motor yacht

Functions

- Lighting
- Air conditioning
- Alarm systems
- Technical monitoring
- Load management
- Multimedia
- Visualisation
- Interfaces to other systems
- Remote monitoring

Scope

Number of KNX devices: 91
Different manufacturers

Costs

95,000 euros

Bus technology ripe for the island

In the luxury Cretan resort, extensive KNX installation ensures comfort and efficiency



Landscape and technology: KNX scenarios conjure up light moods in the evening

Crystal clear water, panoramic view, immaculate beaches, sun all year round, mild climate – the 5-star luxury beach resort Gran Meliá & Luxus Villas Daios Cove in Agios Nikolaos in the north east of the Greek island of Crete scores on all these points. And so much more: 300 rooms, suites and villas, their own swimming pools, charming gardens etc. The resort, which has been built in the tradition of Cretan villages, is also at the peak of technology. 20,000 light sources create light moods at night-time, set scenes in guest accommodation and ensure that the paths are safe. The lighting and other functions are controlled automatically and efficiently via KNX. The great challenge for the system integrator Automationsystems Triantafillidis, was the enormous scope of the resort, which covers 30 hectares and has almost 6800 bus devices, divided on 300 lines, 32 areas and a kilometre long fibre optic network. The solution that was implemented impressed the KNX jury who presented it with the Special Award.

Remote maintenance from the mainland

Time programs, brightness sensors, scenarios and logic functions, control the interior, exterior and architectural lighting. In the conference rooms, blackout blinds, screens, projectors, lifts and dimming functions are integrated in scenarios. Even in the rooms, suites and villas, the ventilation, the heating and the air conditioning devices are activated automatically. Once the guests check in, they are greeted with a pleasant light mode. They can of course specify the lighting in the room themselves via push buttons. Automatic mode is reactivated once the guests leave the room, triggered by a master OFF button or by reception. The superfluous sockets are also switched off. It is convenient feature for the guests that they can signal at the touch of a button that they do not want to be disturbed, or that the room can be cleaned. There is even a plan for the 11 villas whose guests will be able to operate their room functions on the move using an iPad.

Via a KNX visualisation screen, the employees at the reception desk are able to control all the functions on the hotel premises and remain informed about the occupation status of each room and the requirements of the guests regarding the room service. Five touch screens are used for the control and operation of the individual areas such as the swimming pool (spa), the restaurants, the reception desk and the conference rooms. Two further monitors are responsible for managing general hotel functions.

Functional reliability is achieved with a separate bus voltage supply per guest unit. Malfunctions are displayed on a visualisation screen and can be quickly rectified. The problem of the topology is solved using IP routers, which are linked together via a fast fibre optic network for KNX and TCP/IP. One of the technical refinements of the KNX installation is that the entire installation can be maintained remotely via VPN using an OPC server by the system integrator which is located 900 km away, in Thessaloniki.

Benefits provided by KNX in this project

- Automatic lighting control
- Lights can be switched and dimmed individually
- Integration of heating, ventilation and air conditioning
- Increased comfort for guests
- Efficient room management
- Energy saving through time programs and automatic setpoint reduction
- Central operation of individual areas via touch screens
- Monitoring of technical faults
- Remote maintenance

Technical refinements

- Scenarios can be modified or overridden via access rights
- Integration of the media technology
- Simple operation for guests with a service function and central "OFF" switch
- Possible coupling with hotel management, comfort operation with iPad, central BMS
- Networking via IP routers
- Routing with OPC server for remote maintenance

Companies involved

Building owner

Daios Cove Crete,
www.daioscovecrete.com

KNX System Integrator

Automationsystems
Triantafillidis,
www.automationsystems.gr

Area of application:

Luxury hotel, holiday resort

Functions:

- Lighting
- Heating, ventilation, air conditioning
- Technical monitoring
- Energy management
- Audio/video
- Visualisation
- Interfaces to other systems
- Remote monitoring/control

Scope

Number of KNX devices: 6728,
various manufacturers

Costs

1,700,000 euros

Intelligent control makes airport more efficient

Terminal II, Shanghai Hongqiao Airport, equipped with KNX



The control system takes into account natural daylight to implement efficient lighting

In China, the aeroplane is experiencing a rapid increase in use as a fast means of travel and transport. Hongqiao airport, located in the conurbation of Shanghai with 25 million inhabitants, was extended by a second runway and a second terminal to meet this demand. Since 2010, the Shanghai Hongqiao International Airport can handle 300,000 flights and 40 million airline passengers per year. Terminal II, with a main building and boarding corridors with distances of 1.8 and 0.5 kilometres, is designed for 30 million passengers. This tremendous scale indicates the extensive lighting system with approximately 6,000 lighting circuits and their energy consumption. Installing an energy-efficient control system represented a considerable and interesting challenge for the company Shanghai Longchuang Automation Control System Co. Ltd. The perfect solution to this difficult task was presented with the Energy Efficiency Award 2012 by KNX.

It was already evident during the planning phase of the project that the annual energy costs in Terminal II for the lighting alone amount to hundreds of million yuan. A more efficient use of energy with the help of intelligent controllers was therefore called for. These controllers should provide a comfortable level of brightness, which takes into account the daylight streaming in through the glass surfaces and switches on only the artificial lighting when it is required. KNX has already proven itself as a standardised system that is suitable for large airports all over the world. The KNX Technology Team of Siemens Building Technologies in China lent their support to the companies carrying out the installation. The extensive system required more than 3,000 KNX devices distributed across 60 KNX lines to be installed, configured and commissioned. Interior and exterior lighting sensors undertake central functions as well as logic controllers which achieve optimum lighting conditions with efficient use of energy. By using external sensors for the waiting areas near the windows, an exact

adaptation of the brightness level can be achieved. Halogen metal discharge lamps are switched on or off via two brightness thresholds which are automatically adapted to the seasons with a high or low level of sunlight. Lighting circuits are also switched dependent on the flight schedule. To do so, the KNX control communicates with the management system via an OPC server. The brightness level is reduced in areas that are less frequented taking into account the departure or the arrival of the flights. Unnecessary energy consumption is particularly avoided in the period between 21:00 and 8:00. The time- and date-dependent controllers are further energy-saving functions. Lights are switched on or off according to the working days, holidays and time-dependent use. A central control point was implemented using visualisation with the Elvis software and therefore, all the lighting functions can be operated and monitored from here. Time programs can also be modified, setpoint values can be adjusted and loads can be evaluated. The extensive installation is divided into five areas to provide a better overview. The consumption data is regularly transferred to the control unit. Trends in consumption are displayed in graphs which are then used for energy optimisation. Longchuang concludes that KNX has proved itself in this project to be an efficient, reliable and extendable system: "All the requirements of an intelligent lighting control system for efficient energy use could be met. An evaluation of the energy consumption shows that an investment in KNX automation will payback in three to five years".

Benefits provided by KNX in this project

- Energy-efficient lighting control for over 6,000 lighting circuits
- Energy saving through the use of daylight and time- and date-dependent control
- Individual areas can be illuminated precisely according to the flight schedule
- Adapted, comfortable lighting conditions
- Safety through coupling the workplace lighting and emergency lighting with the fire alarm system
- Simple installation, secure investment, extendable system
- Evaluation of the energy consumption via a central visualisation unit

Technical refinements

- Precise adaptation of the brightness level in the window area using external sensors
- Modification of the brightness setpoint values according to the seasons with strong or weak sunlight
- Communication with the flight schedule via OPC server
- Evaluation of the energy consumption via a central visualisation unit

Companies involved

Building owner
Shanghai Airport Authority
Services Engineers, Electrical Engineers, KNX System Integrator
Shanghai Longchuang Automation Control System Co., Ltd

Area of application
Airport

Functions

- Lighting
- Energy management
- Visualisation
- Interfaces to other systems

Scope

Number of KNX devices: 3000, Siemens

Costs
600,000 euros

Diploma with a global standard

Study proves that building automation with KNX is worthwhile

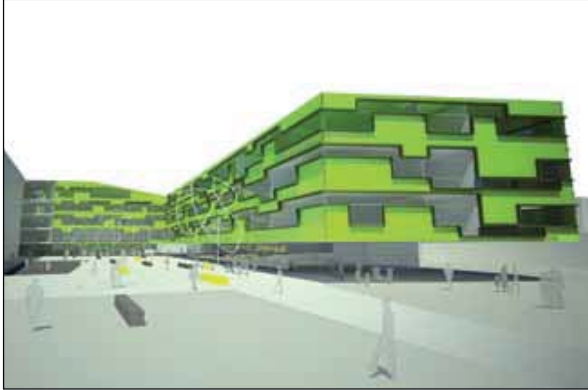

Design of the new school centre: The study recommends the KNX worldwide standard for building technology

The thesis of two students at the St. Pölten polytechnic in Lower Austria is not only the successful conclusion of their studies, but also a study of the school centre building project. Using a sample class, the electrical engineers tested which energy saving potentials can be achieved at different levels of the building automation. The focus lay on the individual room control with KNX. The result: there is a 30 percent saving in thermal energy compared to circuit control. If the window monitoring is also interlinked with the heating valves, a saving of 38 percent can be achieved. If you transfer the result to the entire school centre with 200 classrooms, con-

siderable cost savings can be predicted. The study by Lukas Thallauer and Harald Zeller, under the supervision of their tutors Ing. Gerhard Hinterhofer and DI Gunter Speer, was presented with the Young Award.

Recommendations to the school centre

The Department of Electrical Engineering has been running a KNX training centre for several years, where future technicians can obtain the coveted certificate. It is apparent that the concept study is based on the worldwide applied standard. It incorporates room occupancy, window monitoring, weather conditions, recording of data with the Jung Facility

Pilot, evaluation and optimisation calculations. The aim was to calculate the savings potential and the payback period of the investments. In addition to the installation of KNX components, a Jung Facility Pilot is used for building management with the option of remote monitoring. This reduces the control expenditure of the facility manager as shown by the example of window monitoring. The following were also evaluated: the use of an integrated KNX/DALI lighting control system with emergency lighting and evacuation route lighting, a blind control system with a central weather station, control functions based on the classroom occupation from the timetable, reduction in the room temperature by activating the standby mode via presence sensors. The requirements for thermal energy are sent to the primary control.

The study sees benefits through a reduction in the fire load as a result of an optimised electrical installation with increased flexibility for changes in use and optimisation of the functions.

The achieved result speaks for itself, particularly due to the heating functions with associated weather influences, room occupancy and window states. It is therefore possible for any investments to be paid back within five years. In addition, the study recommends that the new school centre should implement the lighting control including emergency and evacuation route lighting, blind control, several terminals for the building management system as well as media control in the ballroom with KNX.

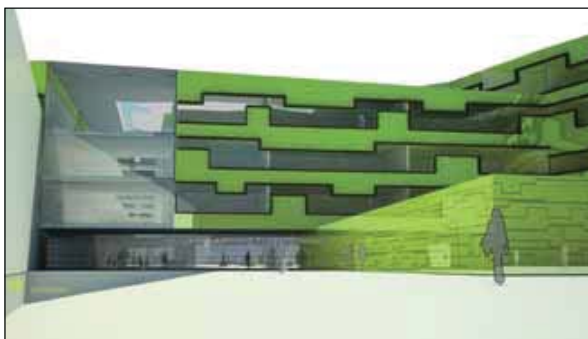

Design of the new school centre:

Main points of the thesis

- Recording of the classrooms
- Calculation of the energy savings
- Additional costs through KNX
- Economic calculations
- Integral concept for all the building services

Companies involved

Building owner
BIG Bundesimmobilien-gesellschaft m.b.H. Austria
Planning and system integration
Department of Electrical Engineering, Ing. Gerhard Hinterhofer

Area of application

School

Functions

- Lighting
- Heating
- Monitoring
- Energy management
- Audio/video
- Visualisation
- Interfaces to other systems
- Remote monitoring/control

Scope

Number of KNX devices: 10

Costs

4000 euros

The Smart Home on the curriculum

Convert theory into practice with KNX



On the KNX test stand, the students can configure and test functions with ETS as they would do in a house

This is how the house of the future will function: the building system observes constantly the energy requirement in each circuits, the energy produced by the photovoltaic system, which is compared with the time variable electricity tariff of the network provider and controls the loads so that they are as energy-efficient and cost-effective as possible. The Darmstadt University of Technology has adopted this in its curriculum.

KNX applications play a major role in converting theoretical knowledge about Smart Grid and Smart Metering into practical awareness. A test stand in the laboratory of the college simulates the technical functions of a complete house, including the generation of solar energy. The students can develop practical methods based on their theoretical subject matter. They get to know ETS and how bus devices are configured and installations are commissioned. As these types of activities are good for the further development of building automation, the idea and the implementation was presented with the KNX Young Award.



The touch screens on the test stands indicate whether the load management functions are as required

Creative ideas for load management

Halogen spotlights as well as switching and dimming actuators simulate the lighting in an apartment. Further lamps with a capacity up to 5 kW and sockets represent all types of loads. A small roller blind with an electric drive and its actuator represents the blind control system. The integration of household appliances in home automation can be practised using the tumble dryer and washing machine installed with miele@home-Technology. Energy loads including standby loads are determined, evaluated and represented via energy actuators and delta meters. This is carried out with a visualisation via a Busch-Jaeger comfort panel, which also links miele@home and the electronic household meters. Meter readings can be visualised via a flush-mounted Busch-Jaeger display connected via KNX RF. An interface to the KNX Eisbär software enables detailed control intervention and the export of measured values to a computer for research purposes. Remote operation with an iPad is also possible.

It is the task of the student to link installations with useful functions and to implement a load management system. This results in sophisticated solutions being implemented. KNX links the electrical loads of the lighting, the sockets, the household appliances and a self-developed KNX charging post for an electric vehicle with the photovoltaic system. With sufficient excess energy, household appliances or vehicle charging can be activated automatically. On the other hand, the loads are adapted to the time variable electricity tariff

Benefits provided by KNX in this project

- Promotes awareness of efficient energy consumption
- Students can convert their theoretical knowledge into practice
- Realisation of creative ideas due to versatile functionality
- Product functions well and is technically sound
- Visualisation and interfaces to other systems
- Support for scientific research through KNX Association

Technical refinements

- Self-developed KNX charging post
- Integration of miele@home and EHZ
- Detailed visualisation of the energy consumption and energy production
- Interfaces to SMA reducer box and SMA PV backup system
- Load management based on Smart Metering and Smart Grid

Functions

- Lighting
- Blind control
- Heating, ventilation, air conditioning
- Energy management
- Visualisation
- Interfaces to other systems
- Remote monitoring/control

Scope

Number of KNX devices: 50, ABB, Busch-Jaeger etc.

Costs

10,000 euros

which is defined by the network provider VNB HSE. Via interfaces to the SMA inverters, the infeed can be reduced or the battery discharge can be controlled.

When choosing to incorporate KNX in the curriculum, the system was praised for its function and installation. According to the organizer, Lutz Steiner, "The fact that KNX Association provides support and suggestions within the framework of a scientific membership, is also a benefit compared to other systems".



The worldwide STANDARD for home and building control

KNX members 300 manufacturers from 34 countries

